

Catalogo Valvole Industria
Industrial Valves Catalogue

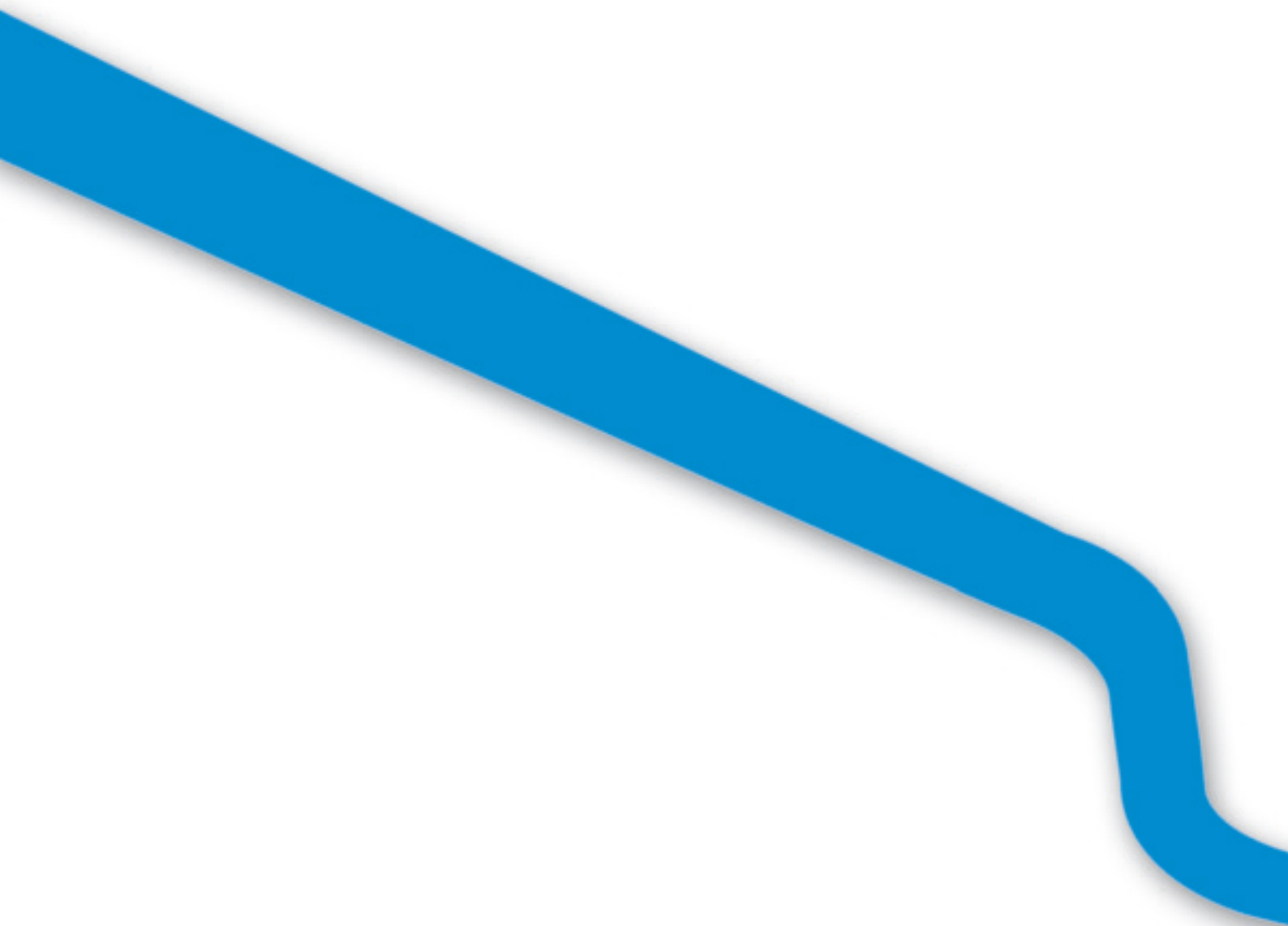



Gentile cliente,

in questo catalogo può trovare l'intera nostra produzione per il settore industriale, costantemente aggiornata grazie all'impegno dell'azienda nell'attività di Ricerca & Sviluppo.

Un'ampia gamma di articoli accompagnati da fotografie, disegni in sezione, diagrammi e dati tecnici, per aiutarvi a scegliere in maniera mirata il prodotto più adatto alle specifiche esigenze.

Per aiutarvi a scegliere la qualità IVR.

Dear Customer,

In this catalogue you may find the whole of our range of valves for industrial use. The range is constantly being developed and updated thanks to the efforts of our R&D activity.

You will find a wide range of products described with photos, section drawings, diagrams, technical data, in order to allow you to choose the most suitable item for the specific application

This will help you choose and appreciate IVR's quality.

Cher Client,

En ce catalogue vous trouverez notre gamme complète de produits pour l'industrie, constamment mise à jour grâce à l'effort et l'engagement de notre société dans l'activité de Recherche et Développement.

Une ample gamme d'articles supportée par images, dessins en sections, diagrammes et données techniques, pour vous aider à choisir de manière visée le produit répondant à vos exigences et **choisir la qualité IVR.**

Veehrter Kunde,

in diesem Katalog finden Sie unsere gesamte Produktion im Bereich Industrie, die dank der Bemühungen des Unternehmens in der Entwicklung, ständig ergänzt und aktualisiert wird!

*Ein breiteres Sortiment von Artikeln, begleitet von Bildern, technischen Daten, 3 D Zeichnungen und Diagrammen, soll Ihnen dabei helfen eine gezieltere Produktwahl zu treffen, die am besten Ihren Bedürfnissen entspricht und natürlich die **IVR-Qualität zu wählen!***

Siamo specializzati nella produzione di valvole a sfera.

Ciò ci ha permesso la messa a punto di metodi di costruzione e l'utilizzo degli ultimi ritrovati tecnologici esistenti sul mercato. Il risultato è un prodotto di qualità superiore agli standard esistenti.

Le valvole vengono prodotte in osservanza stretta delle Normative Europee più recenti. Il nostro Sistema Qualità, certificato secondo la Norma UNI EN ISO 9001: 2000, ci permette di garantire tutta la nostra produzione.

L'ufficio tecnico, con i progettisti e gli addetti alle prove di laboratorio, i responsabili di lavorazione con personale qualificato, l'organizzazione commerciale dinamica ed efficiente, fanno sì che l'azienda si proponga come leader di settore.

We are specialized in the production of ball valves and gate valves.

This has enabled us to develop sophisticated production methods utilising the best of modern technology.

As a result, our quality standards exceed the requirements of all the European and International approval bodies.

This quality system is maintained to UNI EN ISO 9001: 2000, to ensure the ongoing development of our quality systems.

Our design and development department brings together all the expertise within the company, to ensure that we remain at the forefront of technology.

Nous sommes spécialisés dans la production de vannes à sphère.

Ça nous a permis la mise à point de méthodes de fabrication et l'utilisation des dernières nouveautés technologiques existantes dans ce domaine.

Le résultat est un produit de qualité supérieure au standard du marché

Les vannes sont produites suivant les normes européennes les plus récentes.

Notre Système de Qualité, certifié suivant la norme UNI EN ISO 9001: 2000, nous permet de garantir l'intégralité de notre production. Le service technique, avec les projecteurs et les employés en charge des essais, les responsables de la production et le personnel qualifié, l'organisation commerciale, dynamique et efficace, concourent à faire de l'entreprise le leader de son secteur.

Wir sind auf Herstellung von Kugelhaehne spezialisiert. Resultat dieser Spezialisierung sind besonderer. Bearbeitungsverfahren und die Anwendung der neusten Technologie.

Das Ergebnis ist ein Produkt mit überdurchschnittlicher Qualitaet.

Die Ventile werden ausschliesslich nach den aktuell gültigen europaeischen Vorschriften hergestellt. Unser Qualitaetssicherungssystem ist gemaess UNI-EN ISO 9001: 2000 zertifiziert, garantiert eine gleichbleibend Qualitaet der gesamten Produktion.

Bedingt durch unser technisches Büro, Labor, Facharbeiter in der Produktion, sowie dynamische und leistungsfähige Verkaufsabteilung, zählt unser Unternehmen zu den Leadern seiner Branche.

VALVOLE A SFERA

Le valvole con otturatore sferico sono organi di intercettazione dei fluidi e per la loro facilità e rapidità di manovra si sono imposte nell'uso comune al posto di valvole e saracinesche con volantino.

Occorre tuttavia conoscere i loro limiti per una migliore utilizzazione.

- NON SONO ORGANI DI REGOLAZIONE DI FLUSSO PER PERIODI PROLUNGATI, non devono quindi essere usati per questo scopo. Lo scorrimento del fluido NON PULITO sulla parte di guarnizione scoperta ne provoca l'abrasione e quindi la futura perdita.

- NON devono essere usate con acque fangose, fluidi densi, polveri, sostanze viscosi, perché i depositi di materie solide o che si solidificano vanno a bloccare lo scorrimento della sfera.

SUPERATO LO SFORZO MASSIMO di manovra consentito dalle Norme di progettazione, può rompersi l'asta di comando. Per questi fluidi valgono quindi ancora le valvole di arresto o di regolazione alzaschivo.

COLPO D'ARIETE

È il forte aumento di pressione causato dalla interruzione brusca di flusso dell'acqua. Oltre al fastidio del rumore si possono avere altri inconvenienti quali: rotture di giunti, saldature o tubi flessibili.

Il colpo d'ariete è più forte con le tubazioni più piccole e per quelle di grande lunghezza.

Per ovviare a tale inconveniente è consigliabile l'uso di maniglie a manovra lenta (riduttori di manovra).

COIBENTAZIONE

La legge 373/76 Art. 12 Tab. 1 prescrive che il rivestimento minimo abbia uno spessore vicino al diametro esterno della tubazione, per temperature comprese tra -10° e +85°C.

È quindi utile usare la prolunga per maniglia che soddisfa pienamente tali esigenze.

VALVOLE A SFERA FLANGIATE IN OTTONE O GHISA

- La messa in opera di queste valvole deve sottostare ad alcune regole indispensabili per evitare rotture.

- Le flange devono essere corredate di guarnizioni di prima qualità (facce parallele).

- Devono essere perfettamente parallele.

- I bulloni devono essere avvitati a croce (come si fa per le ruote delle auto).

- Devono essere stretti a fondo ma non in modo esagerato.

PN

Pressione max consentita alla temperatura di 80°C.

Per temperature superiori vedere diagramma, rapporto PRESSIONE/TEMPERATURA.

BALL VALVES

Valves with spherical shutter are interception devices for fluids and thanks to their easy and quick handling have come into common use taking the place of valves and sluice valves operated by wheel.

Nevertheless, for a better use, it is necessary to know their limits.

- THEY ARE NOT FLOW CONTROL DEVICES FOR A LONG PERIOD OF TIME, they must not be used for this purpose. The flow of the NON-CLEAN fluid through the uncovered packing causes its consumption and, therefore, the future leakage.

- They must NOT be used with muddy waters, dense fluids, powders viscous substances, because deposits of solid or solidifying materials may block the sliding. The control rod can break by EXCEEDING THE MAXIMUM OPERATION STRESS allowed by the planning rules.

For above fluids, stop valves or control valves male lift are still recommended.

WATER HAMMER

Is the strong pressure increase caused by sudden interruption of water flow. Besides the noise annoyance, other inconveniences may arise such as; cracking of joints, welds or flexible pipes. Water hammer is stronger in case of smaller and longer pipes. In order to avoid such inconvenience it is advisable to use slow operating handles (geared operating reducers).

INSULATION

The law 373/76 Art. 12 Tab. 1 foresees that the minimum coating must have a thickness close to the outside diameter of the pipe, for temperatures from -10° to +85°C. It is therefore useful to use a handle extension which can fully satisfy such demands.

FLANGED BALL VALVES IN BRASS OR CAST IRON

- The laying of above valves must be submitted to some essential rules in order to avoid breaking.

- Flanges must be equipped with first quality packings (parallel sides).

- They must be perfectly parallel.

- Bolts must be screwed down crosswise (like the wheels of a car).

- They must be strongly tightened, but not excessively.

PN

Maximum pressure allowed at 80°C. For higher temperatures see diagram PRESSURE/TEMPERATURE ratio.

SOUPAPES A BILLE

Le soupapes avec obturateur sphérique sont des dispositifs d'interception de fluides et pour leur aisance et rapidité de manoeuvre se sont imposées pour l'usage courant à la place de soupapes et vannes avec volant à main. Toutefois il faut connaître leurs limites pour un meilleur emploi.

- NE SONT PAS DE DISPOSITIFS DE REGLAGE DE L'ÉCOULEMENT POUR DES PÉRIODES PROLONGÉES, et ne doivent pas être utilisées dans ce but. L'écoulement du fluide NON PROPRE sur la partie de garniture découverte peut provoquer son abrasion et, ensuite, la perte future.
- NE DOIVENT PAS être utilisées avec eaux boueuses, fluides denses, poussières ou corps visqueux, parce que les dépôts de matières solides, ou qui se solidifient, bloquent le glissement de la bille. SI ON SURMONT L'EFFORT MAXIMUM DE MANOEUVRE selon les règles de construction, la tige de commande peut se casser. Pour les susdits fluides, donc, on peut encore utiliser les soupapes d'arrêt ou bien de réglage levée mâle.

COUP DE BELIER

C'est le fort accroissement de pression à cause de la brusque interruption de l'écoulement de l'eau. En plus de la gêne du bruit on peut avoir d'autres inconvénients, à savoir: cassure des joints, soudures et tuyaux flexibles. Le coup de bélier est plus fort en cas de tuyauteries plus petites et même plus longues.

Pour obvier à ce inconvénient on conseille l'emploi de poignées à manoeuvre lente (réducteurs de manoeuvre).

CALORIFUGEAU

La loi 373/76 Art. 12 Tab. 1 prescrit que le revêtement minimum ait une épaisseur proche du diamètre extérieur de la tuyauterie, pour températures de -10° à $+85^{\circ}\text{C}$.

Il est utile donc d'employer l'allonge de poignée qui répond parfaitement à telles exigences.

SOUPAPES A BILLE BRIDEES EN LAITON OU EN FONTE

- Pour l'installation de susdites soupapes il faut observer quelques règles indispensables pour éviter des ruptures.
- Les brides doivent être équipées de joints de qualité supérieure (pans parallèles).
- Ces ci doivent être parfaitement parallèles.
- Les boulons doivent être vissés à croix (comme pour les roues des voitures).
- Ces ci doivent être serrés fortement, mais pas d'une manière excessive.

PN

Pression maximum permis à la température de 80°C .

Pour températures supérieures voir le diagramme rapport **PRESSION/TEMPERATUR**

KUGELVENTILE

Die ventile mit kugeligem Verschluss sind Flüssigkeitsperrvorrichtungen, die wegen ihrer Leichtigkeit und Schnellschaltspiel in gewöhnlichen Gebrauch gekommen sind, anstatt Ventile und Schieber mit handrad.

Für eine bessere Verwendung muss man ihre Grenzen kennen.

- *SIE SIND KEINE DURCHFLUSSREGULIERVORRICHTUNGEN FUER LANGE ZEITSPANNE, und, deshalb, müssen sie nicht dafür verwendet werden. Das Fließen der nicht sauberen Flüssigkeiten auf den unbedeckten Dichtungsteil verursacht den Abrieb davon und daher die zukünftige Undichtigkeit.*
- *Sie müssen NICHT mit Schlammwasser, dicken Flüssigkeiten, Stäuben, Zähmitteln verwendet werden, da die Ablagerungen von festen oder zu erstarrenden Stoffen das Gleiten des Kugels verhindern. Sollte die den Planungsvorschriften entsprechende MAXIMALSCHALKRAFT UEBERSCHRITTEN WERDEN, so kann sich die Betätigungsstange brechen. Für obige Flüssigkeiten gelten noch die Absperrventile oder die Kegelhebereinstellventile.*

RUECKSCHLAG

Es handelt sich um eine starke Druckerhöhung die durch eine sprunghafte Wasserstromunterbrechung verursacht wird.

Neben dem lästigen Geräusch können andere Mängel auftreten und zwar: Bruch von Verbindungen, Schweißungen oder Schlauchen. Der Rückschlag ist starker mit den kleinsten und längsten Rohrleitungen.

Um obigen Mangel zu vermeiden ist es die Verwendung von Griffen mit langsamer Betätigung (Betätigungsreduzierer) anzuraten.

ISOLIERUNG

Das Gesetz 373/76 Art. 12 Tab. 1 sieht vor, dass sich die Kleinstumhüllungsstärke dem Ausserdurchmesser der Rohrleitung nähert, bei einer Temperatur von -10° bis $+85^{\circ}\text{C}$. Es ist also die Verwendung einer Griffverlängerung anzuraten, die diesen Anforderungen entspricht.

GEFLANSCHTE KUGELVENTILE AUS MESSING ODER GUSSEISEN

- *Für die Installation obiger Ventile muss man sich an einigen festen Regeln halten, um Brüche zu vermeiden.*
- *Die Flansche müssen mit Dichtungen erster Qualität ausgestattet sein (parallele Seiten).*
- *Sie müssen absolut parallel sein.*
- *Die Schrauben müssen kreuz-weise geschraubt werden (wie bei den Räder eines Fahrzeugs).*
- *Sie müssen fest angezogen sein, aber nicht in übersteigertem Masse.*

PN

Zulässiger Maximaldruck bei einer Temperatur von 80°C . Für höhere Temperaturen siehe das Diagramm **DRUCK/TEMPERATUR** Verhältnis.

CERTIFICAZIONI - CERTIFICATIONS



Il nostro Sistema Qualità Aziendale è certificato secondo ISO 9001: 2000

Our Quality System are assessed and fully comply to ISO 9001: 2000

Le Systeme Qualité de notre société est certifiée selon ISO 9001: 2000

Unser Qualitätssicherungssystem ist zertifiziert nach ISO 9001: 2000



OMOLOGAZIONI INTERNAZIONALI - INTERNATIONAL APPROVALS

I nostri prodotti sono omologati ed approvati dai principali Enti di Certificazione Internazionali.

All our products are approved to the following internationally recognised standards.

Nos produits sont homologés et approuvés par les principaux Organismes Internationaux de Certification.

Bei folgenden international anerkannten Prüfstellen sind unsere Ventile geprüft, zugelassen und zertifiziert.



	Notizie tecniche - <i>Technical information</i>	pag.	5
	Certificazioni - <i>Approval</i>	"	7
IVR 77-78	Flangiata ghisa - <i>Flanged cast iron</i>	"	10-11
IVR 80-81	Flangiata corpo piatto - <i>Flanged cast iron</i>	"	12-13
IVR 97/G - IVR 97/F	Prolunga di manovra - <i>Handle extension</i>	"	25
IVR 170	Valvola di ritegno ghisa - <i>Cast iron swing check valve</i>	"	14
IVR 172	Filtro Y spurgo ghisa - <i>Cast iron Y strainer with drain</i>	"	15
IVR 175	Farfalla tipo LUG - <i>Butterfly valve LUG type</i>	"	16
IVR 176 - IVR 276 CF8M	Farfalla tipo WAFER - <i>Butterfly valve WAFER type</i>	"	17
IVR 179	Riduttore per valvola a farfalla - <i>Gearbox for butterfly valve</i>	"	24
IVR 654	AISI 316 Clapet - <i>AISI 316 swing check valve</i>	"	32
IVR 657	AISI 316 Raccoglitore d' impurità - <i>AISI 316 Inline "Y" strainer</i>	"	33
IVR 660	AISI 316 F/F	"	26-27
IVR 665	AISI 316 tre pezzi FF - <i>AISI 316 three pieces F/F</i>	"	28-29
IVR 670	AISI 316 tre pezzi BW - <i>AISI 316 three pieces BW</i>	"	30-31
IVR 685	AISI 316 Flangiata corpo piatto - <i>AISI 316 flanged slim body</i>	"	34-35
IVR 690	Valvola in acciaio a saldare - <i>Steel ball valve with butt weld connection</i>	"	18-19
IVR 692	Valvola in acciaio flangiata - <i>Steel ball valve with flange ends</i>	"	20-21
IVR 694	Valvola in acciaio flangia saldare - <i>Steel ball valve fully welded</i>	"	22-23

Le caratteristiche dei prodotti possono essere soggette a variazioni senza preavviso.
Product features can change without notice.

FLANGIATA GHISA - IVR 77-78



Valvola a sfera flangiata PN 16. Corpo in ghisa GJL250.
Flangetta ISO 5211.

Cast iron GJL250. Flanged ends PN 16.
with ISO 5211 top for actuator.

Vanne à sphère à brides, PN 16. Corp en fonte GJL250.
Platine ISO 5211.

Kugelhahn mit Flansch PN 16. Körper aus Gusseisen GJL 250.
Mit ISO 5211 Flansch für motorisieren.



IMPIEGHI: Installazioni idrotermosanitarie, acqua surriscaldata, aria compressa, aquedotti, idrocarburi ed olii. ACCESSORI: Prolunga per coibentazione, quadro di manovra, riduttore manuale, attuatore elettrico e pneumatico.

APPLICATIONS: Hydrothermosanitary plants, overheated water, compressed air, waterworks, hydrocarbons and oils. OPTIONS: Stem extensions, square cap, manual, electric and pneumatic actuator.

ART. 78 - Come IVR 77 ma con sfera e asta in acciaio inox AISI 304
ART. 78 - Like IVR 77 but with stainless steel AISI 304 stem and ball



N. N.	DENOMINAZIONE PART NAME	MATERIALE MATERIAL	TRATTAMENTO TREATMENT
1	Corpo - Body	Ghisa GJL250 - Cast iron GJL250	Verniciato - Painted
2	Flangia - Flange	Ghisa GJL250 - Cast iron GJL250	Verniciato - Painted
3	Seggio - Seat	PTFE	
4	Sfera - Ball	Ottone - Brass G-CuZ38Pb2-UNI 5035/62	Cromata - Chrome plated
5	Rondella - Seal	PTFE	
6	Asta - Stem	AVP - 9SMnPb36	
7	O-ring - O-ring	HNBR	
8	Guarniz. asta - Stem seat	PTFE	
9	Premistoppa - Packing nut	Ottone - Brass CW 614N - UNI EN 12164/98	
10	Maniglia - Handle	Acciaio - Steel	Rivest. PVC - Plastic coated
11	Cappuccio - Cap	Ottone - Brass CW 614N - UNI EN 12164/98	Nichelato - Nickel plated
12	Vite - Screw	Acciaio - Steel	Zincato - Zinc plated
13	Vite - Screw	Acciaio - Steel	Zincato - Zinc plated
14	O-ring - O-ring	HNBR	
15	Vite a brugola - Screw	Acciaio - Steel	Zincato - Zinc plated

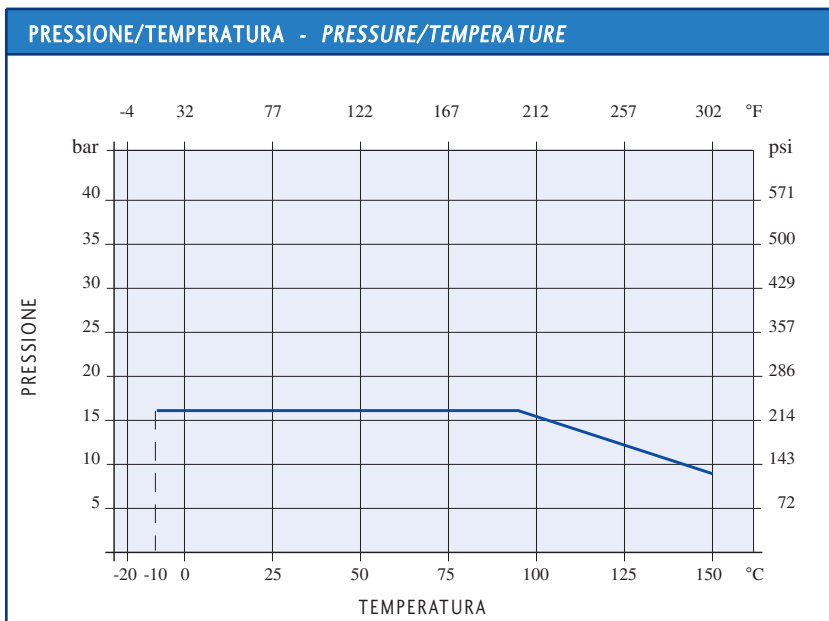
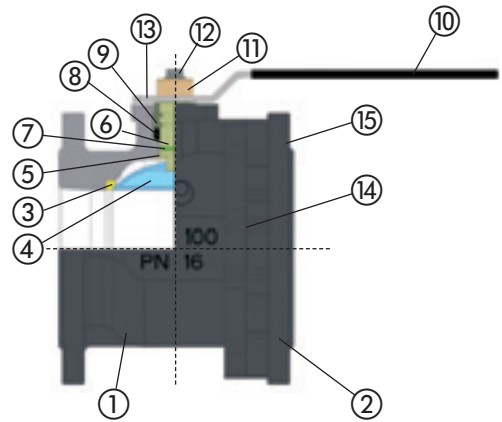

DATI TECNICI - TECHNICAL DATA

Pressione massima di esercizio Max working pressure	16 bar
Temperatura massima di esercizio Max working temperature	-10°C + 150°C
Estremità flangiate Flanged ends	UNI EN 1092
Asta antiscoppio Anti blow-out stem	
Asta con testa quadra 45° Stem with square head 45°	ISO5211.7.3
A richiesta: On request:	Flange - PN 10 Flanges - PN 10

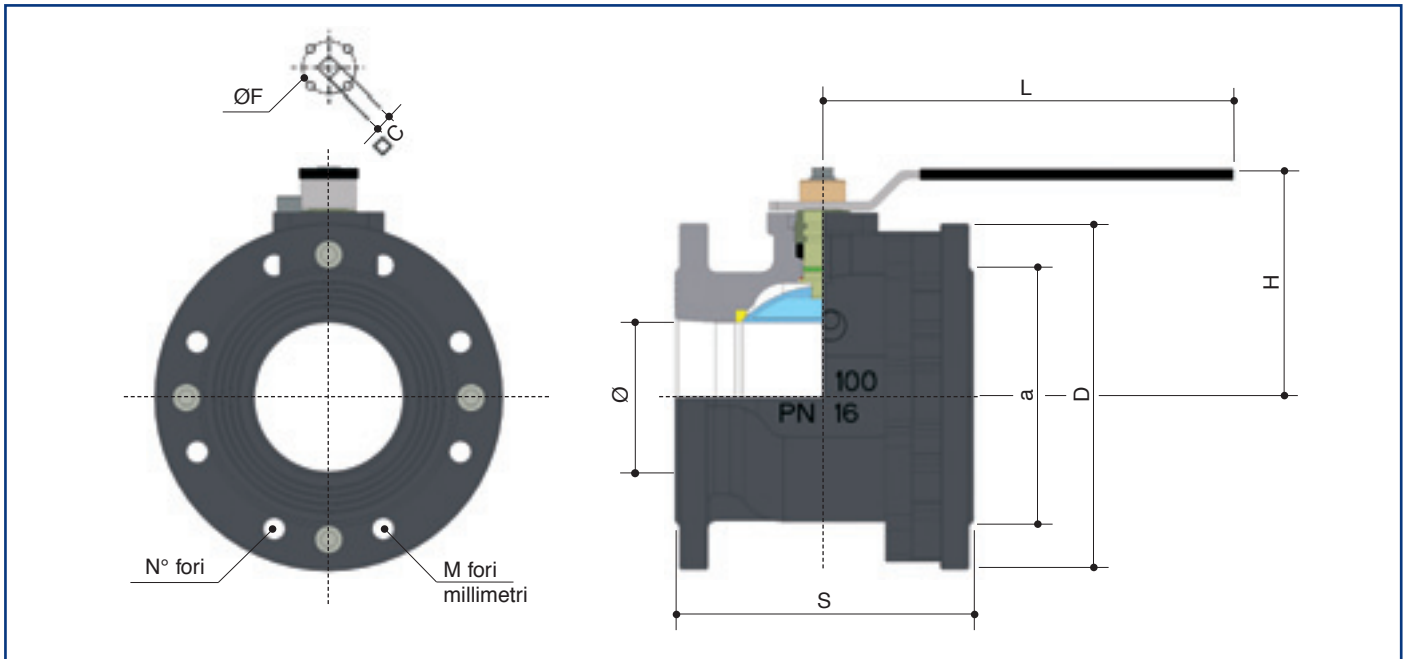

DN	20	25	32	40	50	65	80	100	125	150	200
Ø	20	25	32	40	50	61	74	95	120	145	200
S	120	125	130	140	150	170	180	190	200	210	400
H	73	77	82	92	99	121	130	144	185	204	325
L	200	200	200	240	240	260	260	260	450	450	700
D	105	115	140	150	165	185	200	220	250	285	340
a	75	85	100	110	125	145	160	180	210	240	295
N° fori	4	4	4	4	4	4	8	8	8	8	12
M fori	*	*	*	*	*	*	*	*	M16	M20	
D fori	14	14	18	18	18	18	18	18			Ø22

FI.ISO	F04	F04	F04	F05	F05	F07	F07	F07	F10	F10	
Ø F	42	42	42	50	50	70	70	70	102	102	
□ C	9	9	9	14	14	17	17	17	22	22	

Dimensioni in mm - Dimensions in mm

*Su richiesta - On request

DIAGRAMMA PERDITE DI CARICO - FLOW AND PRESSURE DROP

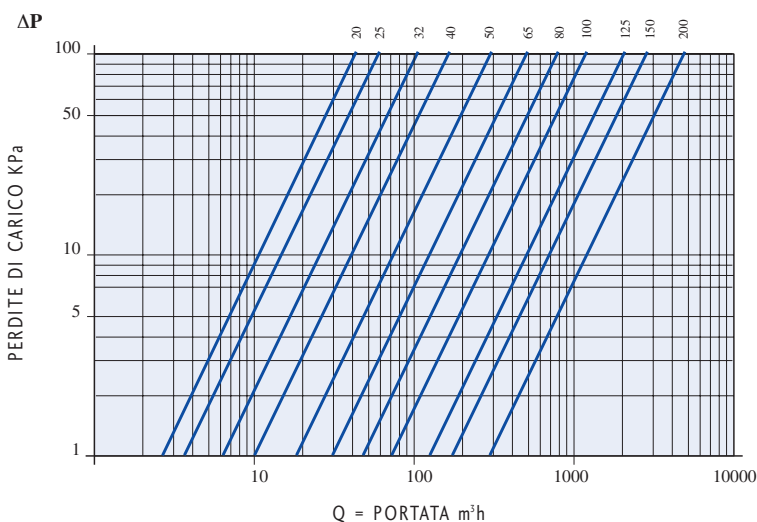

COEFFICIENTE KW - KW FACTOR

DN 20	45
DN 25	60
DN 32	100
DN 40	170
DN 50	265
DN 65	510
DN 80	790
DN 100	1230
DN 125	1900
DN 150	2900
DN 200	5700

FLANGIATA CORPO PIATTO - IVR 80-81



Valvola a sfera a corpo piatto flangiata PN16.

Corpo in ghisa GJL250.

Cast iron GJL250 ball valve.

Flanged ends PN 16.

Vanne à sphère à brides, PN 16.

Corp en fonte GJL250.

Kugelhahn mit Flansch PN 16.

Körper aus Gusseisen GJL250.

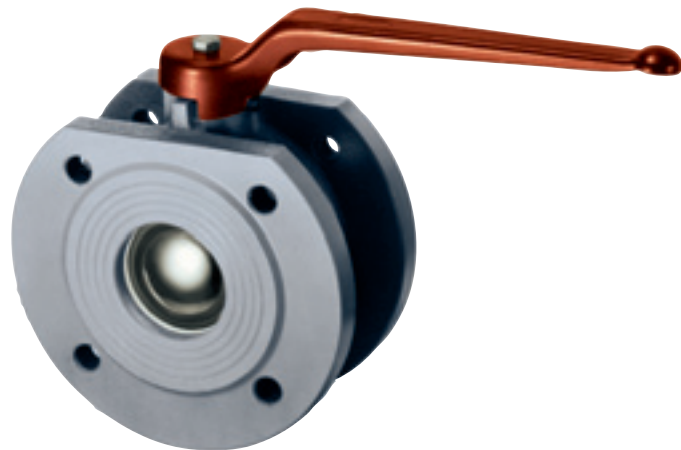

IMPIEGHI: Le valvole a sfera serie 80-81 sono adatte per impiantistica in generale, installazioni idrotermosanitarie, acquedotti, aria compressa, idrocarburi ed olii.

APPLICATIONS: The 80-81 series are a general purpose valve, suitable for use in the hydraulic, sanitary, compressed air industries, hydrocarbons and oils.

ART. 81 - Come IVR 80 ma con sfera in acciaio inox AISI 304

ART. 81 - Like IVR 80 but with stainless steel AISI 304 ball



N. N.	DENOMINAZIONE PART NAME	MATERIALE MATERIAL	TRATTAMENTO TREATMENT
1	Corpo - Body	Ghisa GJL250 - Cast iron GJL250	Verniciato - Painted
2	Flangia - Flange	Ghisa GJL250 - Cast iron GJL250	Verniciato - Painted
3	Seggio - Seat	PTFE	
4	Sfera - Ball	Ottone - Brass G-CuZ38Pb2-UNI 5035/62	Cromata - Chrome plated
5	Asta - Stem	Ottone - Brass CW 614N - UNI EN 12164/98	
6	Guarniz. asta - Stem seat	PTFE	
7	Premistoppa - Packing nut	Ottone - Brass CW 614N - UNI EN 12164/98	
8	O-ring - O-ring	NBR	
9	Maniglia - Handle	Acciaio - Steel	Verniciato - Painted
10	Vite - Screw	Acciaio - Steel	Zincato - Zinc plated

Nota: Disponibile su richiesta verniciato RAL 7032

Note: Available on request painted RAL 7032

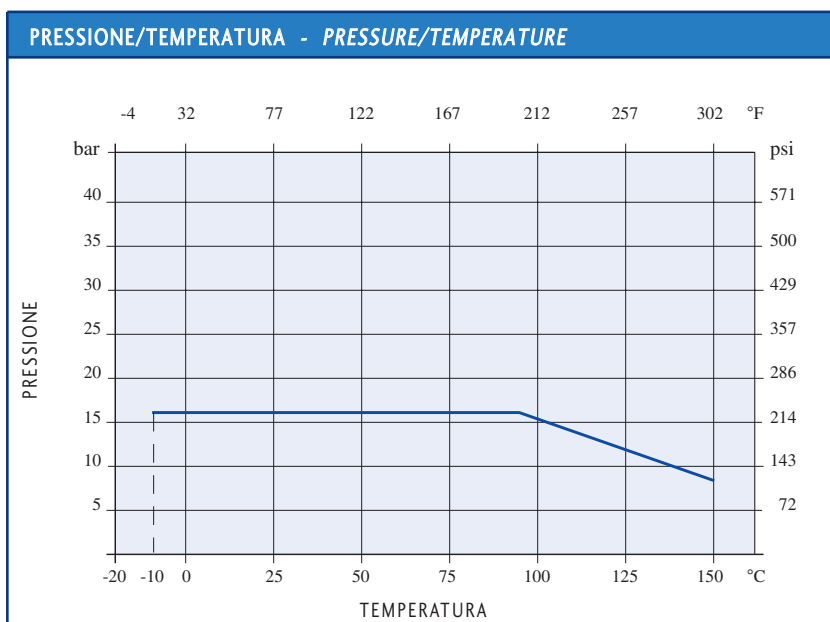
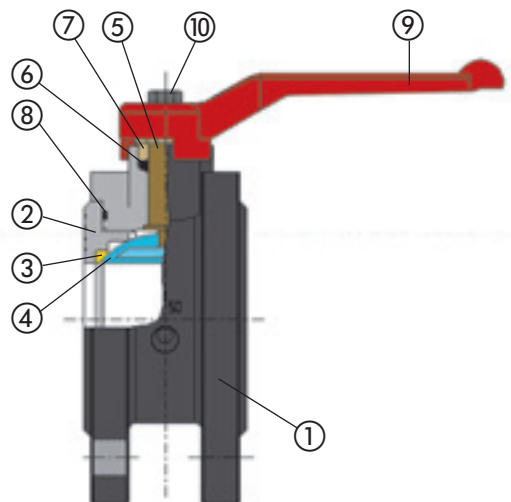

DATI TECNICI - TECHNICAL DATA

Pressione massima di esercizio Max working pressure	16 bar
Temperatura massima di esercizio Max working temperature	-10°C + 150°C
Estremità flangiate Flanged ends	UNI - EN 1092
Asta antiscoppio Anti blow-out stem	

FLANGIATA CORPO PIATTO - IVR 80-81

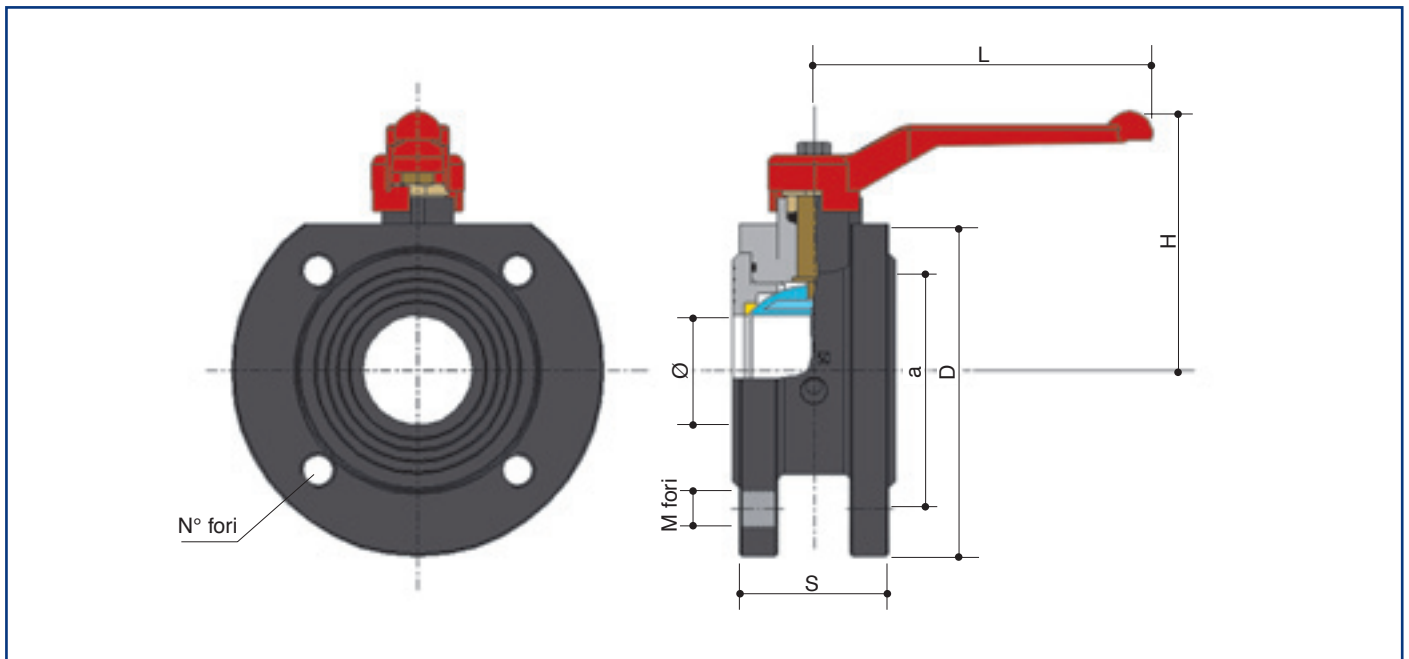

DN	20	25	32	40	50	65	80	100
Ø	20	25	32	40	50	61	74	95
S	40	50	55	62	80	100	120	130
H	82	92	98	105	112	144	154	144
L	125	150	150	150	150	240	240	260
D	105	115	140	150	165	185	200	220
a	75	85	100	110	125	145	160	180
N° fori	4	4	4	4	4	4	8	8
M fori	M12	M12	M16	M16	M16	M16	M16	M16

Dimensioni in mm - Dimensions in mm

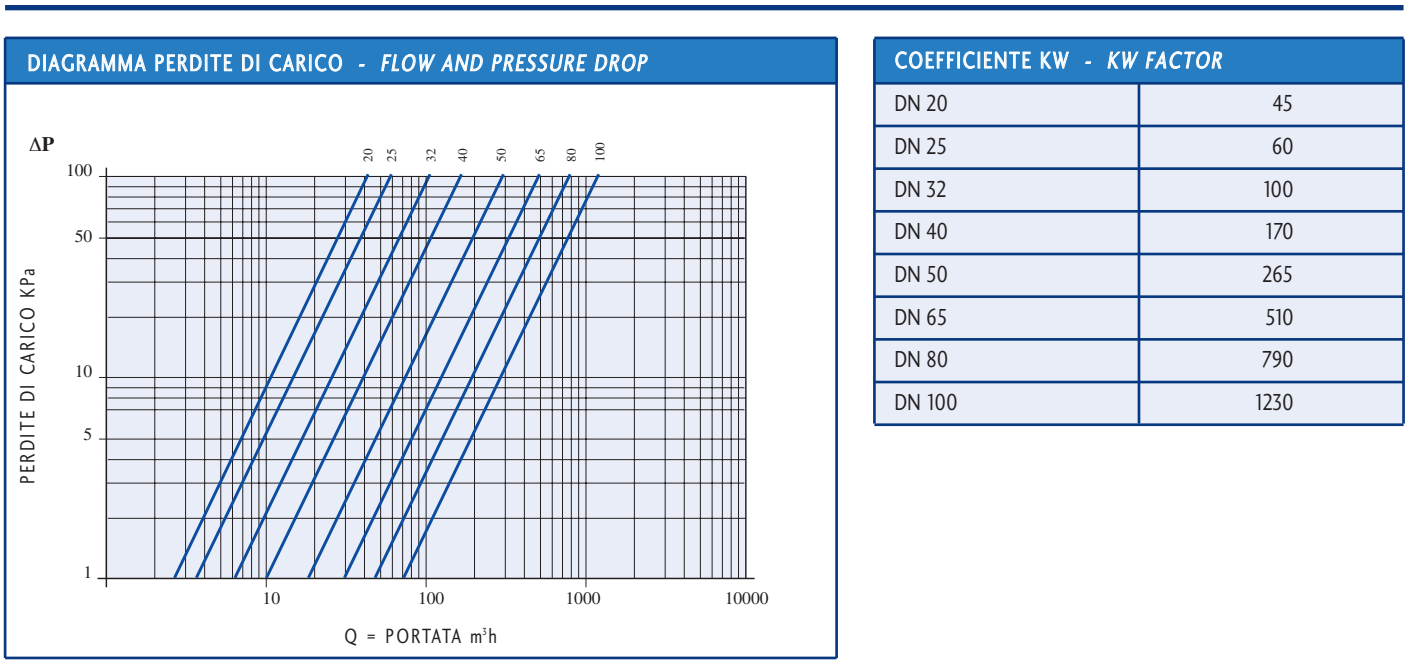

VALVOLA DI RITEGNO A CLAPET GHISA - IVR 170



Valvola di ritegno a clapet flangiata PN 16. Corpo in ghisa GJL500.

Cast iron GJL500 swing check valve - flanged ends PN 16.

Soupape de retenue à clapet à brides, PN 16. Corpe en fonte GJL500.

Rückschlagventil mit Flanschen PN 16. Körper aus Gusseisen GJL500.



IMPIEGHI: Installazioni idrotermosanitarie, acquedotti, depurazione, antincendio.

APPLICATIONS: Hydrothermosanitary plants, aqueducts, waste water, fire safety system.

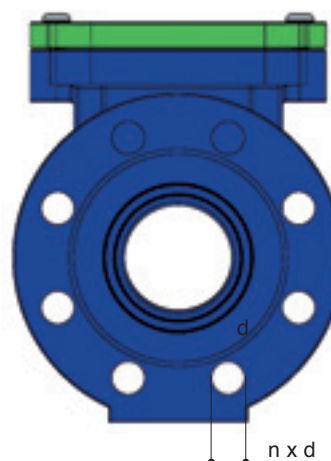
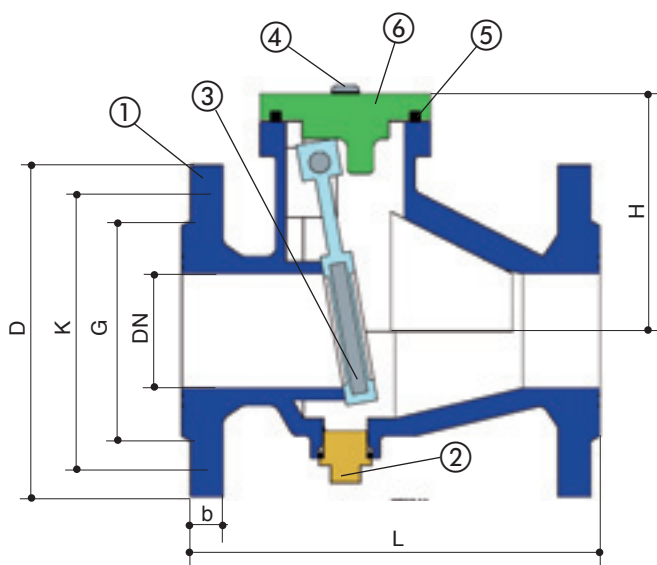

N. N.	DENOMINAZIONE PART NAME	MATERIALE MATERIAL	TRATTAMENTO TREATMENT
1	Corpo - Body	Ghisa GJS500 - Cast iron GJS500	Verniciato - Painted
2	Tappo - Plug	Acciaio inox - Stainless steel AISI 304	
3	Disco - Disc	Acciaio rivest. NBR Steel NBR coated	
4	Bullone - Bolt	Acciaio - Steel	
5	Guarnizione - Gasket	NBR	
6	Coperchio - Bonnet	Ghisa GJS500 - Cast iron GJS500	Verniciato - Painted

DN	50	65	80	100	125	150	200	250	300
L	200	240	260	300	350	400	500	600	700
H	115	125	140	150	165	180	205	246	285
b	19	19	19	19	19	19	20	24	26
G	104	118	134	160	182	212	270	320	370
K	125	145	160	180	210	240	295	355	410
D	165	185	200	220	250	285	340	405	460
n x d	4x19	4x19	8x19	8x19	8x19	8x23	12x23	12x28	12x28

Dimensioni in mm - Dimensions in mm

DATI TECNICI - TECHNICAL DATA	
Pressione massima di esercizio Max working pressure	PN 16
Temperatura massima di esercizio Max working temperature	-10°C + 80°C
Estremità flangiata Flanged ends	UNI - EN 1092

FILTRO Y SPURGO GHISA - IVR 172



Filtro a Y con spurgo flangiato PN 16 - corpo in ghisa GJL500
 Cast iron GJS 500 Y strainer with drain - flanged ends PN 16
 Filtres en Y à purge à brides, PN 16. Corpe en fonte GJL500
 Y-Schmutzfänger mit Ablass-Anschluss, Flanschen PN 16.
 Körper aus Gusseisen GJL500.



IMPIEGHI: Installazioni idrotermosanitarie, acquedotti, depurazione, antincendio.
 APPLICATIONS: Hydrothermosanitary plants, aqueducts, waste water, fire safety system.

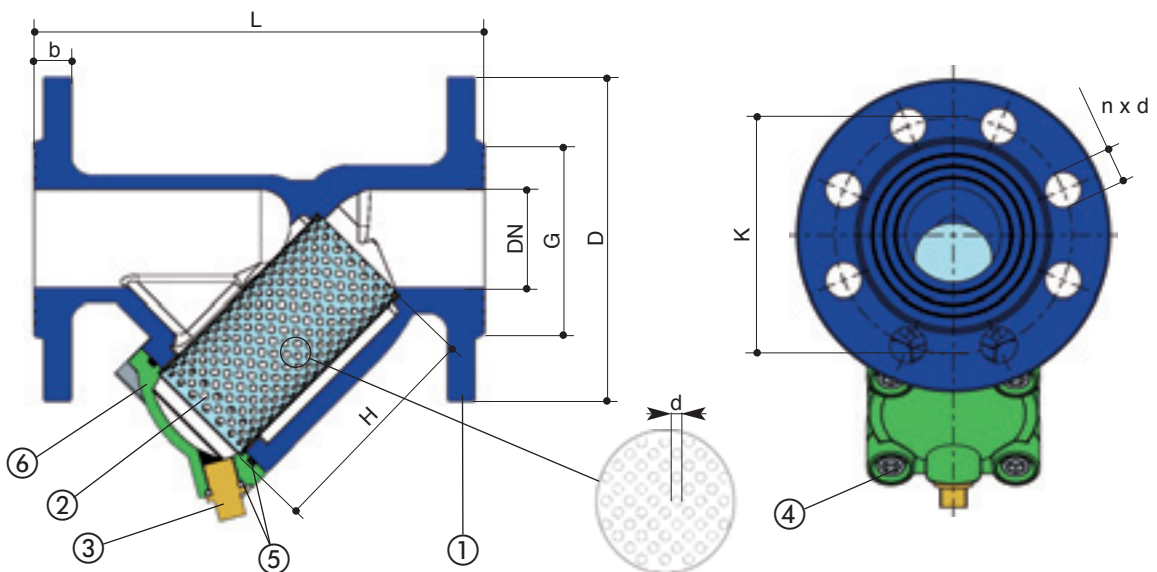

N. N.	DENOMINAZIONE PART NAME	MATERIALE MATERIAL	TRATTAMENTO TREATMENT
1	Corpo - Body	Ghisa GJS500 - Cast iron GJS500	Verniciato - Painted
2	Filtro - Screen	Acciaio inox - Stainless steel AISI 304	
3	Tappo - Plug	Acciaio - Steel	
4	Bullone - Bolt	Acciaio - Steel	
5	O-ring - O-ring	EPDM	
6	Coperchio - Bonnet	Ghisa GJS500 - Cast iron GJS500	Verniciato - Painted

DN	50	65	80	100	125	150	200
L	230	290	310	350	400	480	600
H	125	132	138	140	209	250	335
D	165	185	200	220	250	285	340
G	104	118	134	160	182	212	270
K	165	185	200	220	250	285	340
b	19	19	19	19	19	19	20
d	1.5	1.5	1.5	1.5	1.5	1.5	2
n x d	4x19	4x19	8x19	8x19	8x19	8x23	12x23

Dimensioni in mm - Dimensions in mm

DATI TECNICI - TECHNICAL DATA	
Pressione massima di esercizio Max working pressure	PN 16
Temperatura massima di esercizio Max working temperature	-10°C + 80°C
Estremità flangiate Flanged ends	UNI - EN 1092

FARFALLA TIPO LUG - IVR 175



Valvola farfalla tipo Lug.
Butterfly valve Lug type.
Vanne à papillon type Lug.
Absperklappe.



IMPIEGHI: le valvole a farfalla tipo Lug IVR 175 sono adatte per impianti idrici, riscaldamento, condizionamento, applicazioni industriali ed agricole, aria compressa.

APPLICATIONS: the butterfly valves Lug type IVR 175 are suitable for use in water supply, heating, air conditioning, industrial, irrigation and compressed air system.



N. N.	DENOMINAZIONE PART NAME	MATERIALE MATERIAL	TRATTAMENTO TREATMENT
1	Corpo - Body	Ghisa GJL250 - Cast iron GJL250	Verniciato - Painted
2	Otturatore - Disc	Ghisa GJL250 - Cast iron GJL250	Nichelato - Nickel plated
3	Guarnizione - Seat	EPDM	
4	Asta - Stem	AISI 416	
5	O-ring - O-ring	EPDM	
6	Boccola - Bushing	Ottone - Brass	
7	Divisore - Retainer	Acciaio - Steel	
8	Leva - Lever	Acciaio - Steel	Verniciato - Painted

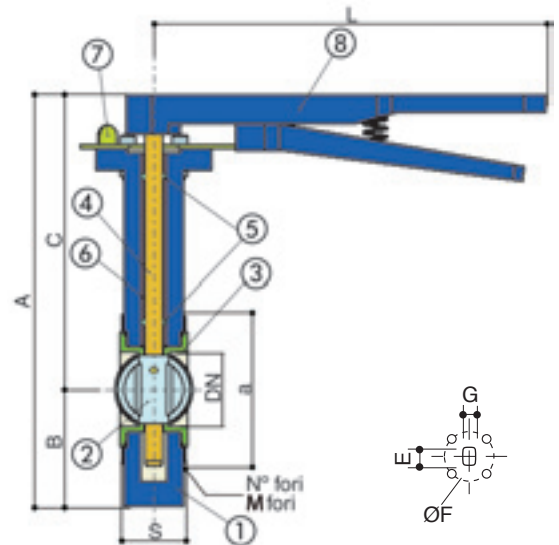

DN	40	50	65	80	100	125	150	200	250	300
A	252	273	296	308	346	372	397	480	540	624
B	70	80	89	95	114	127	139	175	203	242
C	182	193	207	213	232	245	258	305	337	382
S	35	45	48	49	55	58	59	63	70	80
L	165	165	265	265	265	265	265	355	500	500
a	110	125	145	160	180	210	240	295	355	410
N° fori	4	4	4	8	8	8	8	12	12	12
M fori	M16	M16	M16	M16	M16	M16	M20	M20	M24	M24
Ø F	7	7	7	7	10	10	10	12	12	14
E	12	12	12	12	14	18	18	22	28	28
G	9	9	9	9	11	14	14	17	22	22
FL ISO	F05	F05	F05	F05	F07	F07	F07	F10	F10	F12

DATI TECNICI - TECHNICAL DATA	
Pressione massima di esercizio Max working pressure	16 bar
Temperatura massima di esercizio Max working temperature	-10°C + 100°C

Dimensioni in mm - Dimensions in mm

FARFALLA TIPO WAFER - IVR 176 - IVR 276 CF8M



Valvola farfalla tipo Wafer.
 Vanne à papillon type Wafer.
 Butterfly valve Wafer type.
 Absperrklappe.



IMPIEGHI: le valvole a farfalla tipo Wafer IVR 176 sono adatte per impianti idrici, riscaldamento, condizionamento, applicazioni industriali ed agricole, aria compressa.

APPLICATIONS: the butterfly valves Wafer type IVR 176 are suitable for use in water supply, heating, air conditioning, industrial, irrigation and compressed air system.

ART. 276 CF8M - Come IVR 176 ma con otturatore in acciaio inox CF8M
 ART. 276 CF8M - Like IVR 176 but with stainless steel CF8M disc



N. N.	DENOMINAZIONE PART NAME	MATERIALE MATERIAL	TRATTAMENTO TREATMENT
1	Corpo - Body	Ghisa GJL250 - Cast iron GJL250	Verniciato - Painted
2	Otturatore - Disc	Ghisa GJL250 - Cast iron GJL250	Nichelato - Nickel plated
3	Guarnizione - Seat	EPDM	
4	Asta - Stem	AISI 416	
5	O-ring - O-ring	EPDM	
6	Boccola - Bushing	Ottone - Brass	
7	Divisore - Retainer	Acciaio - Steel	
8	Leva - Lever	Acciaio - Steel	Verniciato - Painted

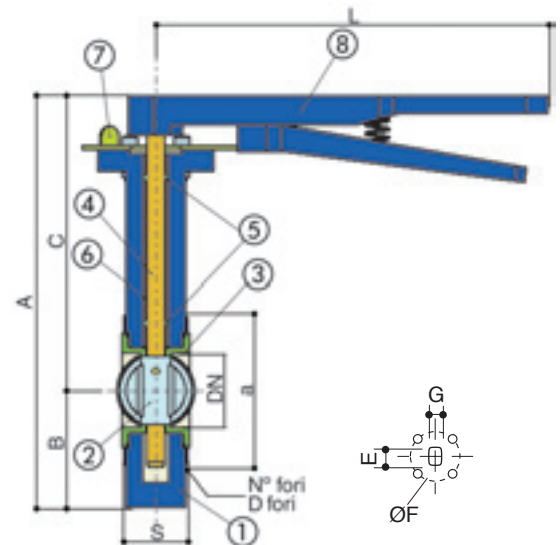

DN	40	50	65	80	100	125	150	200	250	300
A	252	273	296	308	346	372	397	480	540	624
B	70	80	89	95	114	127	139	175	203	242
C	182	193	207	213	232	245	258	305	337	382
S	35	45	48	49	55	58	59	63	70	80
L	165	165	265	265	265	265	265	355	500	500
a	110	125	145	160	180	210	240	295	355	410
N° fori	4	4	4	8	8	8	8	12	12	12
D fori	19	19	19	19	19	19	23	23	28	28
Ø F	7	7	7	7	10	10	10	12	12	14
E	12	12	12	12	14	18	18	22	28	28
G	9	9	9	9	11	14	14	17	22	22
FL ISO	F05	F05	F05	F05	F07	F07	F07	F10	F10	F12

DATI TECNICI - TECHNICAL DATA	
Pressione massima di esercizio Max working pressure	16 bar
Temperatura massima di esercizio Max working temperature	-10°C + 100°C

Dimensioni in mm - Dimensions in mm

VALVOLA IN ACCIAIO A SALDARE - IVR 690

Valvola a sfera in acciaio completamente saldata

Connessioni a saldare di testa.

Steel ball valve fully welded

With butt weld connection.

Vanne à sphère en acier entièrement soudée

Raccordement à souder BW.

Edelstahlkugelhahn mit Anschluss

zum löten/schweißen



IMPIEGHI: impianti di teleriscaldamento e di raffreddamento, acqua surriscaldata, aria compressa.

APPLICATIONS: district heating and cooling systems, overheated water, pressured air.



N. N.	DENOMINAZIONE PART NAME	MATERIALE MATERIAL	TRATTAMENTO TREATMENT
1	Corpo - Body	Acciaio - Steel	Verniciato - Painted
2	O-ring - O-ring	FPM	
3	Asta - Stem	Acciaio inox - Stainless steel	
4	Cappuccio - Cap	Ottone - Brass	Nichelato - Nickel plated
5	Vite - Screw	Acciaio - Steel	Zincato - Zinc plated
6	Maniglia - Handle	Acciaio - Steel	Rivest. PVC - Plastic coated
7	Spina - Pin	Acciaio inox - Stainless steel	
8	Rondella antifrizione Friction washer	P.T.F.E.	
9	Sfera - Ball	Acciaio inox - Stainless steel	
10	Guarnizione - Seal	P.T.F.E. + C	
11	Anello - Ring	Acciaio inox - Stainless steel	
12	Anello elastico Elastic ring	Acciaio - Steel	
13	Anello intermedio Intermediate ring	Acciaio - Steel	

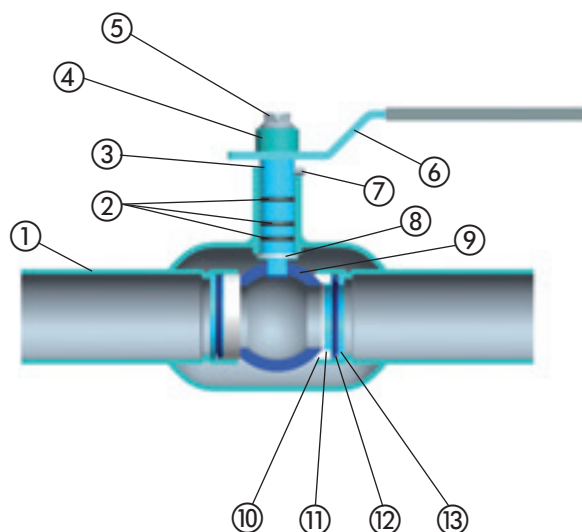

PRESSIONE/TEMPERATURA - PRESSURE/TEMPERATURE

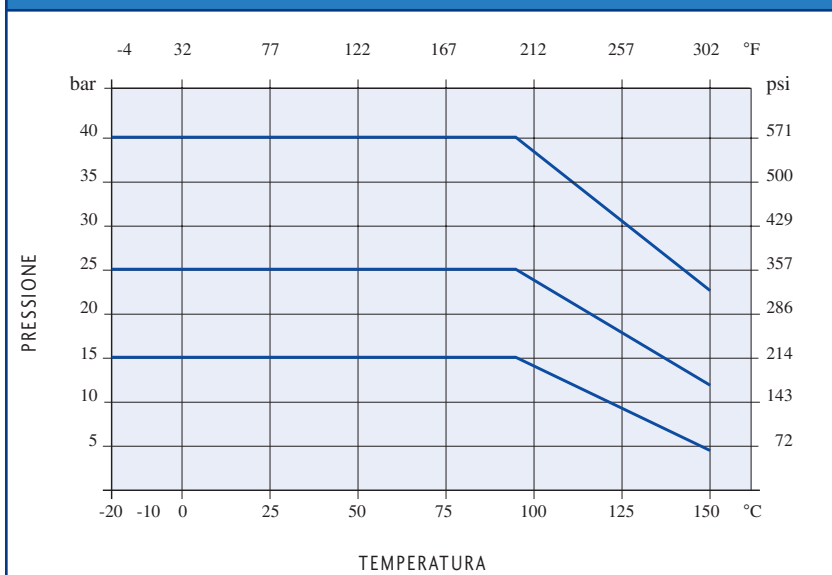

DATI TECNICI - TECHNICAL DATA

Pressione massima di esercizio Max working pressure	DN 20 - DN 50 40 bar DN 65 - DN 100 25 bar DN 125 DN 200 16 bar
Temperatura massima di esercizio Max working temperature	-30°C + 200°C

VALVOLA IN ACCIAIO A SALDARE - IVR 690

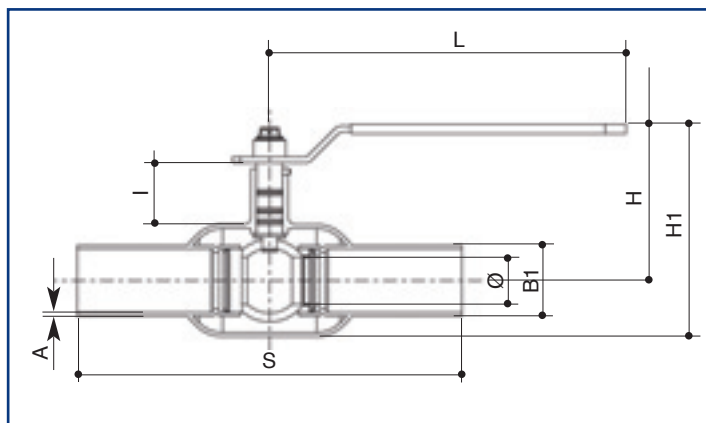

DN	20*	25	32	40	50	65	80	100	125*	150*	200*
Ø		20	25	32	38	48	60	77			
A		2,8	2,8	2,8	3	3,5	4	4			
B1		33,7	42,4	48,3	57	76	89	108			
L		200	200	240	240	240	320	320			
H		95	97	110	110	120	160	175			
H1		123	125	144	151	160	220	250			
S		230	262	260	300	360	370	390			
I		45	45	45	45	40	65	60			

Dimensioni in mm - Dimensions in mm
 * Di prossima produzione - * Available soon

DIAGRAMMA PERDITE DI CARICO - FLOW AND PRESSURE DROP

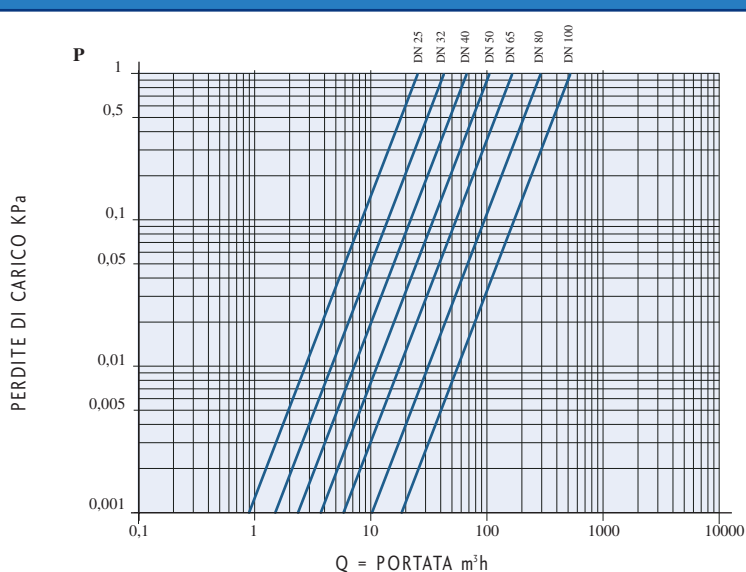

COEFFICIENTE KW - KW FACTOR

DN 20	
DN 25	26
DN 32	41
DN 40	68
DN 50	110
DN 65	160
DN 80	290
DN 100	420
DN 125	
DN 150	
DN 200	

VALVOLA IN ACCIAIO FLANGIATA - IVR 692

Valvola a sfera in acciaio completamente saldata

Connessioni flangiate.

Steel ball valve fully welded

With flange ends.

Vanne à sphère en acier entièrement soudée

Raccordement à brides.

Edelstahlkugelhahn mit Flanschanschluss



IMPIEGHI: impianti di teleriscaldamento e di raffreddamento, acqua surriscaldata, aria compressa.

APPLICATIONS: district heating and cooling systems, overheated water, pressured air.

N. N.	DENOMINAZIONE PART NAME	MATERIALE MATERIAL	TRATTAMENTO TREATMENT
1	Corpo - Body	Acciaio - Steel	Verniciato - Painted
2	O-ring - O-ring	FPM	
3	Asta - Stem	Acciaio inox - Stainless steel	
4	Cappuccio - Cap	Ottone - Brass	Nichelato - Nickel plated
5	Vite - Screw	Acciaio - Steel	Zincato - Zinc plated
6	Maniglia - Handle	Acciaio - Steel	Rivest. PVC - Plastic coated
7	Spina - Pin	Acciaio inox - Stainless steel	
8	Rondella antifrizione Friction washer	P.T.F.E.	
9	Sfera - Ball	Acciaio inox - Stainless steel	
10	Guarnizione - Seal	P.T.F.E. + C	
11	Anello - Ring	Acciaio inox - Stainless steel	
12	Anello elastico Elastic ring	Acciaio - Steel	
13	Anello intermedio Intermediate ring	Acciaio - Steel	

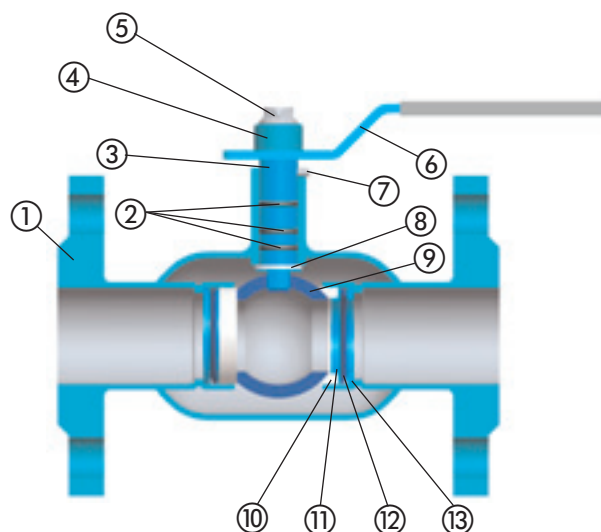

PRESSIONE/TEMPERATURA - PRESSURE/TEMPERATURE

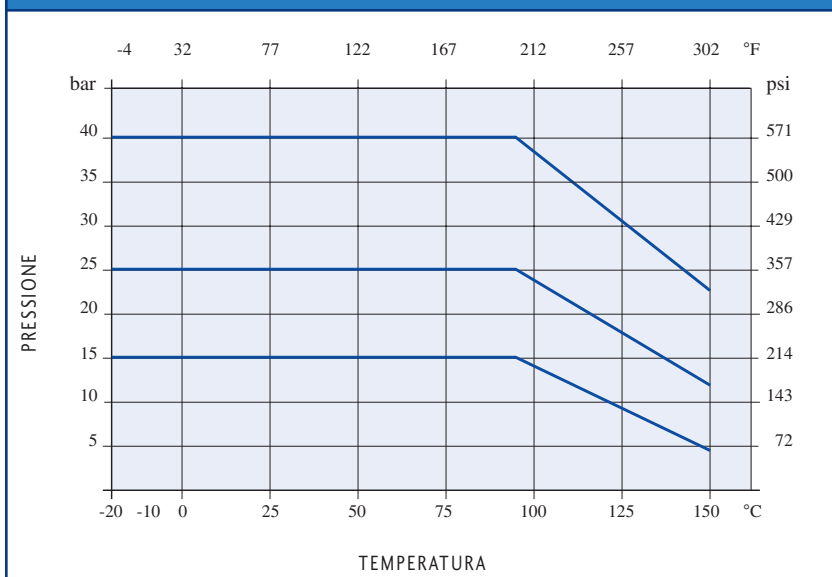

DATI TECNICI - TECHNICAL DATA

Pressione massima di esercizio Max working pressure	DN 20 - DN 50 40 bar DN 65 - DN 100 25 bar DN 125 DN 200 16 bar
Temperatura massima di esercizio Max working temperature	-30°C + 200°C

VALVOLA IN ACCIAIO FLANGIATA - IVR 692

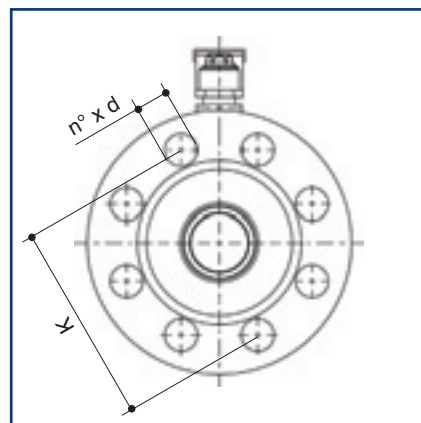
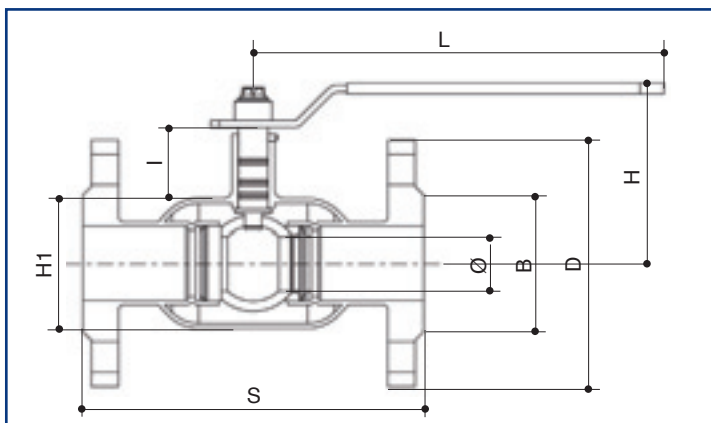

DN	20*	25	32	40	50	65	80	100	125*	150*	200*
Ø		20	25	32	38	48	60	77			
K		84	100	110	124	145	160	190			
B		70	80	89	105	125	138	163			
D		115	140	150	165	185	200	235			
L		200	200	240	240	240	320	320			
H		95	97	110	110	120	160	175			
H1		51	57	77	83	102	121	152			
S		160	180	200	230	270	280	300			
I		35	37	35	37	35	55	51			
n° x d		4x14	4x18	4x18	4x18	8x18	8x18	8x22			

Dimensioni in mm - Dimensions in mm
 * Di prossima produzione - * Available soon

DIAGRAMMA PERDITE DI CARICO - FLOW AND PRESSURE DROP

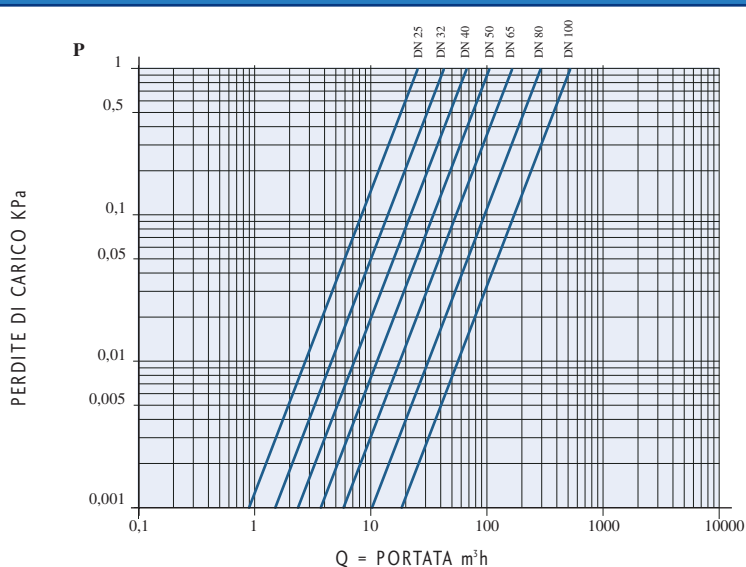

COEFFICIENTE KW - KW FACTOR

DN 20	
DN 25	26
DN 32	41
DN 40	68
DN 50	110
DN 65	160
DN 80	290
DN 100	420
DN 125	
DN 150	
DN 200	

VALVOLA IN ACCIAIO FLANGIA - SALDARE - IVR 694

Valvola a sfera in acciaio completamente saldata
 Conessioni flangiata / saldare di testa.

Steel ball valve fully welded

With flange / butt weld connection.

Vanne à sphère en acier entièrement soudée

Raccordement à brides / souder BW.

Edelstahlkugelhahn Kombination mit Flanschanschluss und

Anschluss zum löten/schweißen



IMPIEGHI: impianti di teleriscaldamento e di raffreddamento, acqua surriscaldata, aria compressa.

APPLICATIONS: district heating and cooling systems, overheated water, pressured air.

N. N.	DENOMINAZIONE PART NAME	MATERIALE MATERIAL	TRATTAMENTO TREATMENT
1	Corpo - Body	Acciaio - Steel	Verniciato - Painted
2	O-ring - O-ring	FPM	
3	Asta - Stem	Acciaio inox - Stainless steel	
4	Cappuccio - Cap	Ottone - Brass	Nichelato - Nickel plated
5	Vite - Screw	Acciaio - Steel	Zincato - Zinc plated
6	Maniglia - Handle	Acciaio - Steel	Rivest. PVC - Plastic coated
7	Spina - Pin	Acciaio inox - Stainless steel	
8	Rondella antifrizione Friction washer	P.T.F.E.	
9	Sfera - Ball	Acciaio inox - Stainless steel	
10	Guarnizione - Seal	P.T.F.E. + C	
11	Anello - Ring	Acciaio inox - Stainless steel	
12	Anello elastico Elastic ring	Acciaio - Steel	
13	Anello intermedio Intermediate ring	Acciaio - Steel	

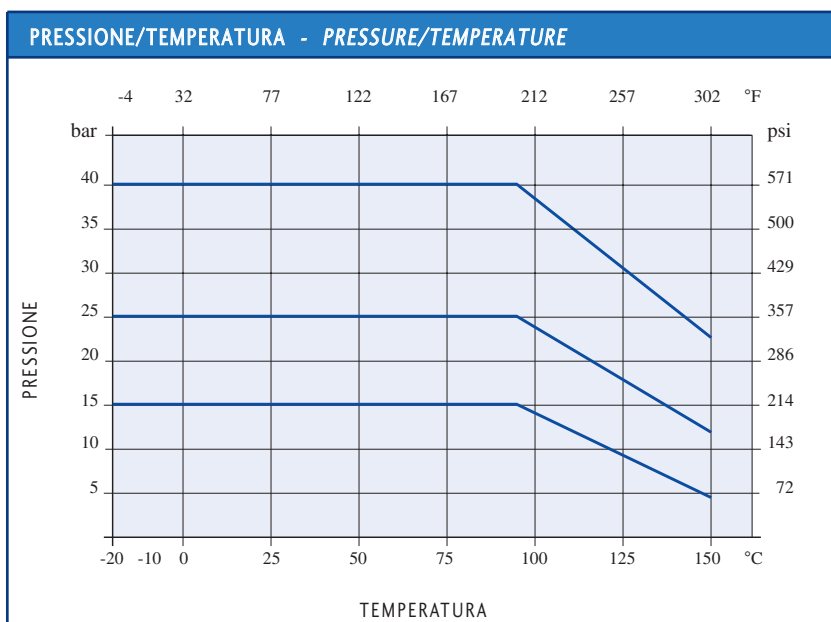
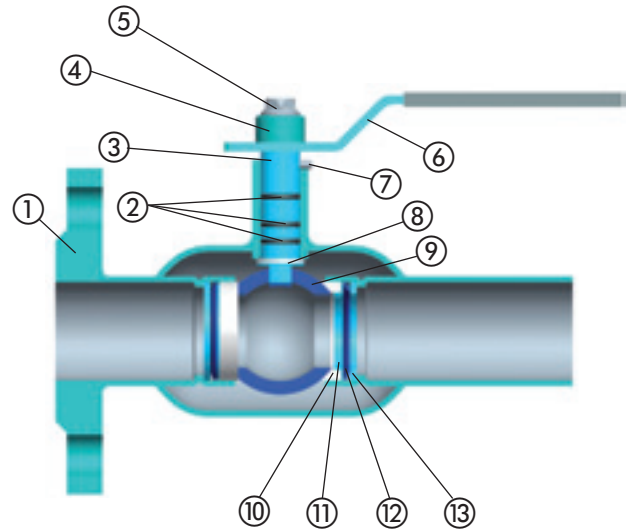

DATI TECNICI - TECHNICAL DATA

Pressione massima di esercizio Max working pressure	DN 20 - DN 50 40 bar DN 65 - DN 100 25 bar DN 125 DN 200 16 bar
Temperatura massima di esercizio Max working temperature	-30°C + 200°C

VALVOLA IN ACCIAIO FLANGIA - SALDARE - IVR 694

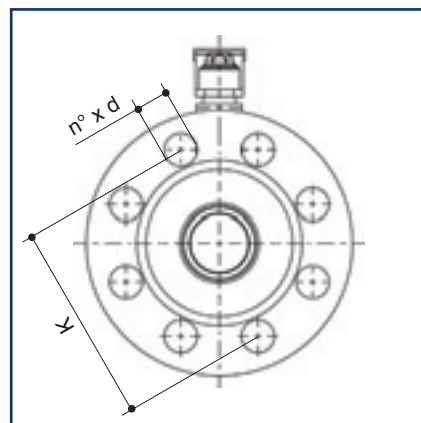
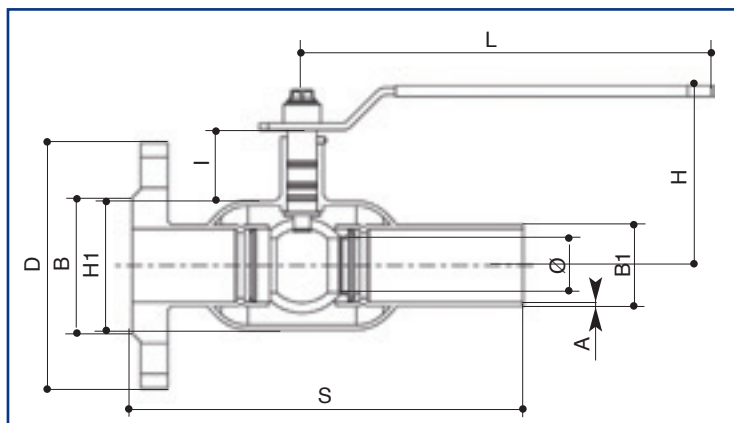

DN	20*	25	32	40	50	65	80	100	125*	150*	200*
Ø		20	25	32	38	48	60	77			
K		84	100	110	124	145	160	190			
B		70	80	89	105	125	138	163			
B1		33,7	42,4	48,3	57	76	89	108			
D		115	140	150	165	185	200	235			
A		4,5	3,6	3,8	3,7	3,5	4	4			
L		200	200	240	240	240	320	320			
H		95	97	110	110	120	160	175			
H1		51	57	77	83	102	121	152			
S		195	220	230	265	315	325	345			
I		35	37	35	37	35	55	51			
n° x d		4x14	4x18	4x18	4x18	8x18	8x18	8x22			

Dimensioni in mm - Dimensions in mm
 * Di prossima produzione - * Available soon

DIAGRAMMA PERDITE DI CARICO - FLOW AND PRESSURE DROP

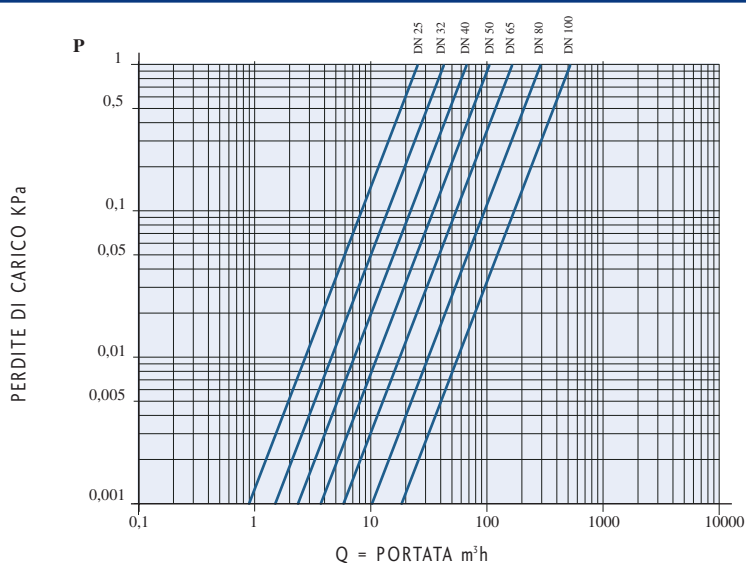

COEFFICIENTE KW - KW FACTOR

DN 20	
DN 25	26
DN 32	41
DN 40	68
DN 50	110
DN 65	160
DN 80	290
DN 100	420
DN 125	
DN 150	
DN 200	

RIDUTTORE PER VALVOLA A FARFALLA TIPO LUG - WAFER - IVR 179



Riduttore di manovra per valvola a farfalla con kit di viti per il montaggio
IVR 175 - IVR 176 - IVR 276 CF8M

Gearbox for butterfly valve with screw kit for the assembly
IVR 175 - IVR 176 - IVR 276 CF8M

Reducteur pour vanne à papillon avec kit de vis pour le montage
IVR 175 - IVR 176 - IVR 276 CF8M

Mit schrauben für montage.
IVR 175 - IVR 176 - IVR 276 CF8M



DN	100	125	150	200	250	300
A	105	105	105	150	150	162
B	50	50	50	80	80	81
C	45	45	45	69	69	77,5
D	150	150	150	300	300	300
h	175	175	175	300	300	310
H	200	200	200	305	305	310
ISO-F	F07	F07	F07	F10	F10	F12

Dimensioni in mm - Dimensions in mm

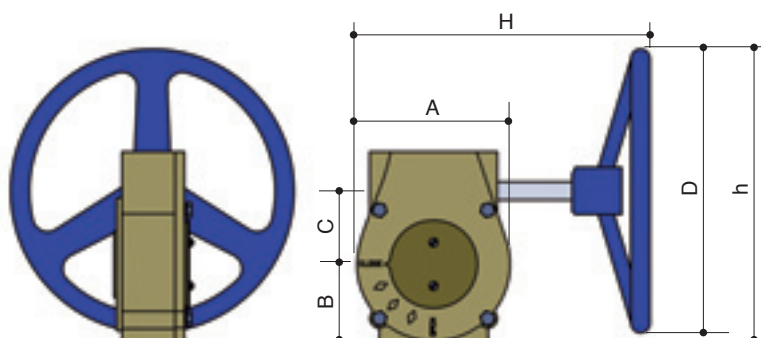

PROLUNGA - IVR 97/G - IVR 97/F



Prolunga di manovra per isolamento termico.

Handle extension for thermal insulation.

Rallonge fixe pour calorifugeage.

Spindel verlängerung.

IMPIEGHI: Permette il rivestimento con materiale da coibentazione contro la dispersione del calore ed a temperature inferiori a -10°C.

APPLICATIONS: To permit to covering by insulation material in order to avoid heat dispersions at temperature lower than the -10°C.

IVR 97/G: in dotazione viti di fissaggio.
IVR 97/G: kit assembling screws and nuts.

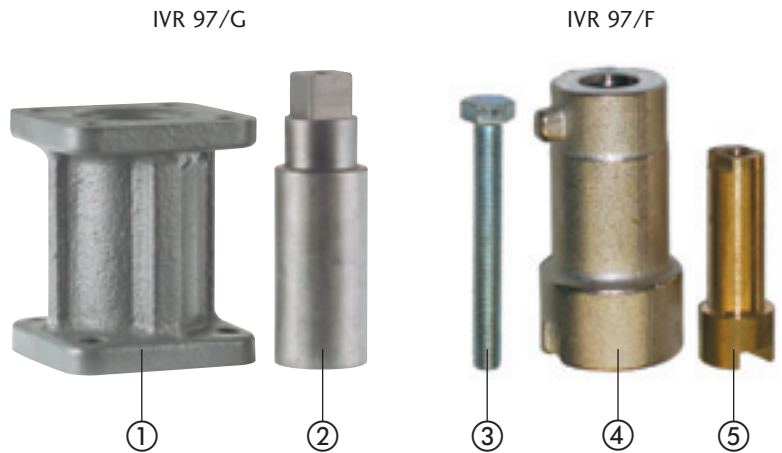

N. N.	DENOMINAZIONE PART NAME	MATERIALE MATERIAL	TRATTAMENTO TREATMENT
1	Prolunga - Extension	Ghisa GJL250 - Cast Iron GJL250	Verniciato - Painted
2	Asta - Stem	Acciaio - Steel	
3	Vite - Screw	Acciaio - Steel	
4	Prolunga - Extension	Ottone - Brass CW 617N - UNI EN 12165/98	Nichelato - Nickel plated
5	Asta - Stem	Ottone - Brass CW 614N - UNI EN 12164/98	

Prolunga	2aG	3aG	5aG	6aG	IVR 97/G
Alzata H	55	60	85	105	

Prolunga	3aF	4aF	5aF	IVR 97/F
Alzata H	74	93	107	

Dimensioni in mm - Dimensions in mm

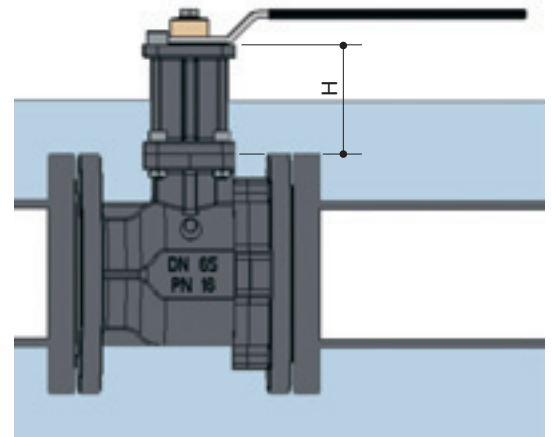

Scelta della misura di prolunga - Choice of extension stem size										
Valvole flangiate	20	25	32	40	50	65	80	100	125	150
IVR 77-78	2aG	2aG	2aG	3aG	3aG	5aG	5aG	5aG	6aG	6aG
IVR 82-83	2aG	2aG	2aG	3aG	3aG	5aG	5aG	5aG	6aG	6aG

IVR 97/G

Scelta della misura di prolunga - Choice of extension stem size										
Valvole flangiate			32	40	50	65	80	100		
IVR 80			3a	3a	3a	4a	4a	5a		
IVR 81			3a	3a	3a	4a	4a	5a		

IVR 97/F

AISI 316 FF - IVR 660



Valvola a sfera a passaggio totale in acciaio inox AISI316.
 Attacchi filettati gas F/F.

AISI316 stainless steel full bore ball valve.

Threaded ends F/F.

Vanne à sphère à passage integral en acier inox AISI316.

Tarudage pas gaz F/F.

Kugelhahn mit vollem Durchgang aus Edelstahl AISI316.

Anschlussgewinde I/I.



IMPIEGHI: Le valvole a sfera serie 660 sono adatte per impianti industriali, chimici ed alimentari.

APPLICATIONS: The 660 series are suitable for use in industrial, chemical and food plants.



N. N.	DENOMINAZIONE PART NAME	MATERIALE MATERIAL	TRATTAMENTO TREATMENT
1	Corpo - Body	AISI316	
2	Manicotto - Body end	AISI316	
3	Seggio - Seat	PTFE caricato 15% vetro PTFE 15% glassfiber	
4	Sfera - Ball	AISI316	
5	Asta - Stem	AISI316	
6	Rondella - Seal	PTFE	
7	Guarn. asta - Stem seat	PTFE	
8	Premistoppa - Packing nut	AISI304	
9	Maniglia - Handle	AISI304	Rivestimento PVC - PVC coated
10	Dado - Nut	AISI304	
11	Bloccaggio - Locking	AISI304	

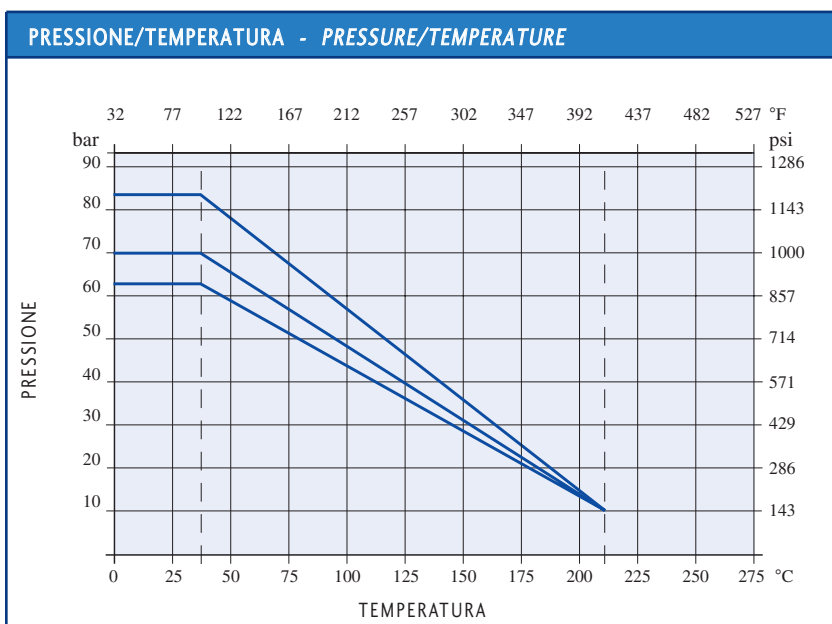
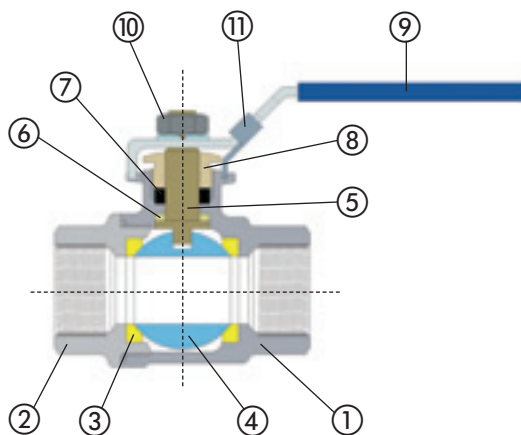

DATI TECNICI - TECHNICAL DATA

Pressione massima di esercizio <i>Max working pressure</i>	1/4" - 1" 85 bar 1"1/4" - 1"1/2" 70 bar 2" - 4" 65 bar	
Temperatura massima di esercizio <i>Max working temperature</i>	-40°C + 220°C	
Filettatura estremità <i>Threaded ends</i>	UNI ISO 228/1	
Asta anticoppio <i>Anti blow-out stem</i>		
A richiesta: On request:	filettatura thread	NPT ANSI B.1.20.1

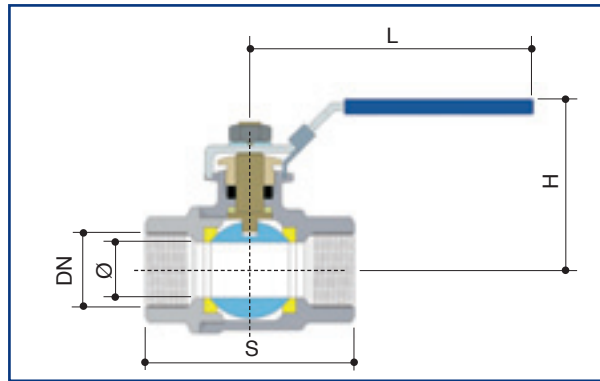

DN	1/4"	3/8"	1/2"	3/4"	1"	1"1/4	1"1/2	2"	2"1/2	3"	4"
Ø	11,5	12,5	15	20	25	32	38	50	62	76	94
S	49	49	55	66	78,5	90	98,5	120	147	172	220
H	48	48	52	57	75	80	95	96	125	135	160
L	100	100	100	115	150	150	180	180	245	245	278

Dimensioni in mm - Dimensions in mm

DIAGRAMMA PERDITE DI CARICO - FLOW AND PRESSURE DROP

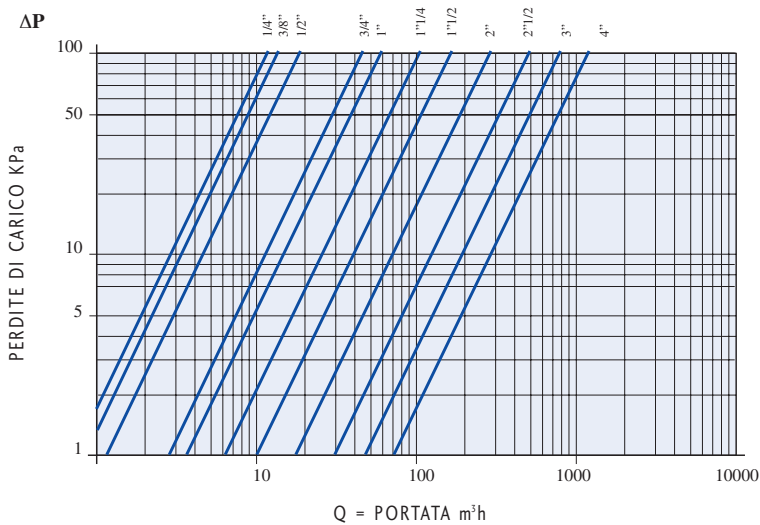

COEFFICIENTE KW - KW FACTOR

1/4" - 11,6	16
3/8" - 12,7	18
1/2" - 15	20
3/4" - 20	45
1" - 25	60
1"1/4 - 32	100
1"1/2 - 40	170
2" - 50	265
2"1/2 - 65	510
3" - 76	790
4" - 94	1230

AISI 316 TRE PEZZI FF - IVR 665



Valvola a sfera a passaggio totale in tre pezzi in acciaio inox AISI316.
 Attacchi filettati gas F/F - Flangetta ISO 5211.

*AISI316 stainless steel three pieces full bore ball valve.
 Threaded ends F/F - ISO 5211 top for actuator.*

Vanne à sphère à passage intégral trois pièces en acier inox AISI316.
 Taraudage pas gaz F/F - Platine ISO 5211.

*Kugelhahn mit vollem Durchgang aus Edelstahl AISI316.
 Anschlussgewinde I/I - Flansch ISO 5211.*



IMPIEGHI: Le valvole a sfera serie 665 sono adatte per impianti industriali, chimici ed alimentari.

APPLICATIONS: The 665 series are suitable for use in industrial, chemical and food plants.



N. N.	DENOMINAZIONE PART NAME	MATERIALE MATERIAL	TRATTAMENTO TREATMENT
1	Corpo - Body	AISI316	
2	Manicotto - Body end	AISI316	
3	Seggio - Seat	PTFE caricato 15% vetro PTFE 15% glassfiber	
4	Guarniz. corpo - Body seal	PTFE	
5	Sfera - Ball	AISI316	
6	Asta - Stem	AISI316	
7	Rondella - Washer	PTFE	
8	Guarn. asta - Stem seal	PTFE	
9	Premistoppa - Packing nut	AISI304	
10	Maniglia - Handle	AISI304	Rivestimento PVC - PVC coated
11	Bloccaggio - Locking	AISI304	
12	Dado - Nut	AISI304	
13	Arresto - Stop pin	AISI304	
14	Dado - Nut	AISI304	
15	Bullone - Bolt	AISI304	

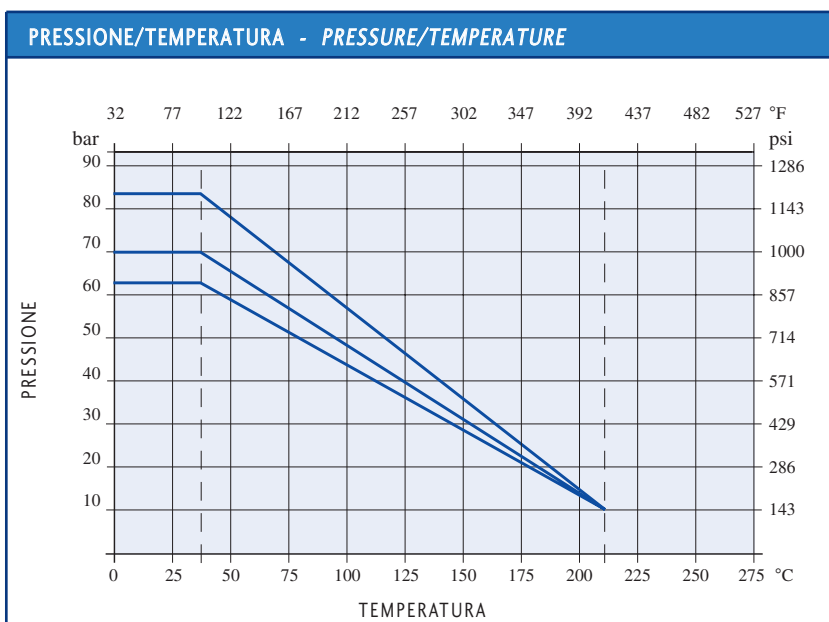
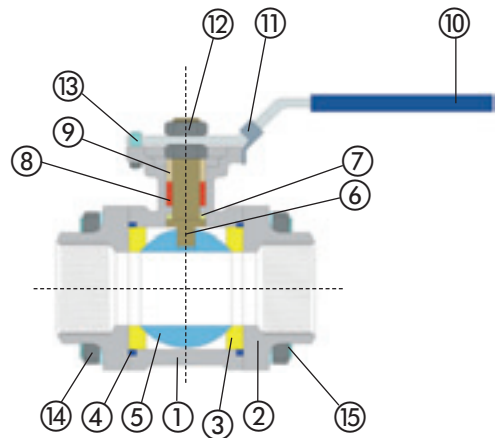

DATI TECNICI - TECHNICAL DATA		
Pressione massima di esercizio Max working pressure	1/4" - 1" 85 bar 1"1/4" - 1"1/2" 70 bar 2" - 4" 65 bar	
Temperatura massima di esercizio Max working temperature	-40°C + 220°C	
Filettatura estremità Threaded ends	UNI ISO 7/1 R	
Asta antiscooppio Anti blow-out stem		
Asta con testa quadra 45° Stem with square head 45°	ISO5211.73	
A richiesta: On request:	filettatura thread	NPT ANSI B.1.20.1

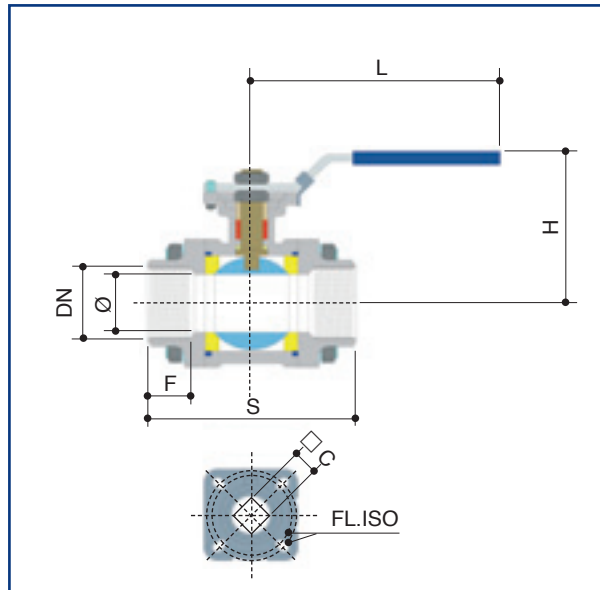

DN	1/4"	3/8"	1/2"	3/4"	1"	1 1/4"	1 1/2"	2"	2 1/2"	3"	4"
Ø	11	12,7	15	20	25	32	40	50	65	80	100
S	48	48	55	74	81	91	103	120	142	182	220
F	10	11	15	16	19	21	21	25	30	33	39
H	62	63	68	72	75	90	95	102	140	162	170
L	117	117	117	135	135	203	203	203	260	260	280
□ C	9	9	9	11	11	14	14	14	17	17	17
FL.ISO	F03	F03	F03	F04/F05	F04/F05	F05/F07	F05/F07	F05/F07	F07/F10	F07/F10	F07/F10

Dimensioni in mm - Dimensions in mm

DIAGRAMMA PERDITE DI CARICO - FLOW AND PRESSURE DROP

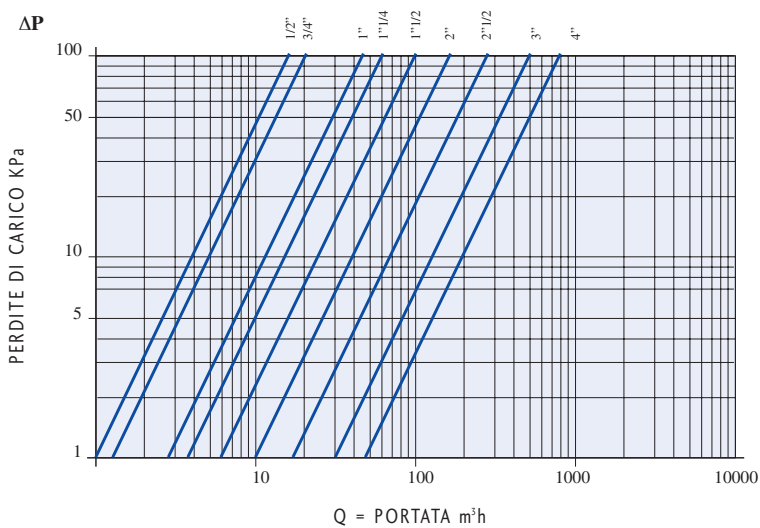

COEFFICIENTE KW - KW FACTOR

1/4"	15
3/8"	15
1/2"	20
3/4"	45
1"	60
1 1/4"	100
1 1/2"	170
2"	265
2 1/2"	510
3"	790
4"	1230

AISI 316 TRE PEZZI BW - IVR 670



Valvola a sfera a passaggio totale in tre pezzi in acciaio inox AISI316.

Attacchi a saldare di testa - Flangetta ISO 5211.

AISI316 stainless steel three pieces full bore ball valve.

Butt welding ends - ISO 5211 top for actuator.

Vanne à sphère à passage intégral trois pièces en acier inox AISI316.

Extrémités à souder butt welding - Platine ISO 5211.

Kugelhahn mit vollem Durchgang aus Edelstahl AISI316.

Ende butt welding - Flansch ISO 5211.



IMPIEGHI: Le valvole a sfera serie 670 sono adatte per impianti industriali, chimici ed alimentari.

APPLICATIONS: The 670 series are suitable for use in industrial, chemical and food plants.

N. N.	DENOMINAZIONE PART NAME	MATERIALE MATERIAL	TRATTAMENTO TREATMENT
1	Corpo - Body	AISI316	
2	Manicotto - Body end	AISI316	
3	Seggio - Seat	PTFE caricato 15% vetro PTFE 15% glassfiber	
4	Guarniz. corpo - Body seal	PTFE	
5	Sfera - Ball	AISI316	
6	Asta - Stem	AISI316	
7	Rondella - Washer	PTFE	
8	Guarn. asta - Stem seal	PTFE	
9	Premistoppa - Packing nut	AISI304	
10	Maniglia - Handle	AISI304	Rivestimento PVC - PVC coated
11	Bloccaggio - Locking	AISI304	
12	Dado - Nut	AISI304	
13	Arresto - Stop pin	AISI304	
14	Dado - Nut	AISI304	
15	Bullone - Bolt	AISI304	

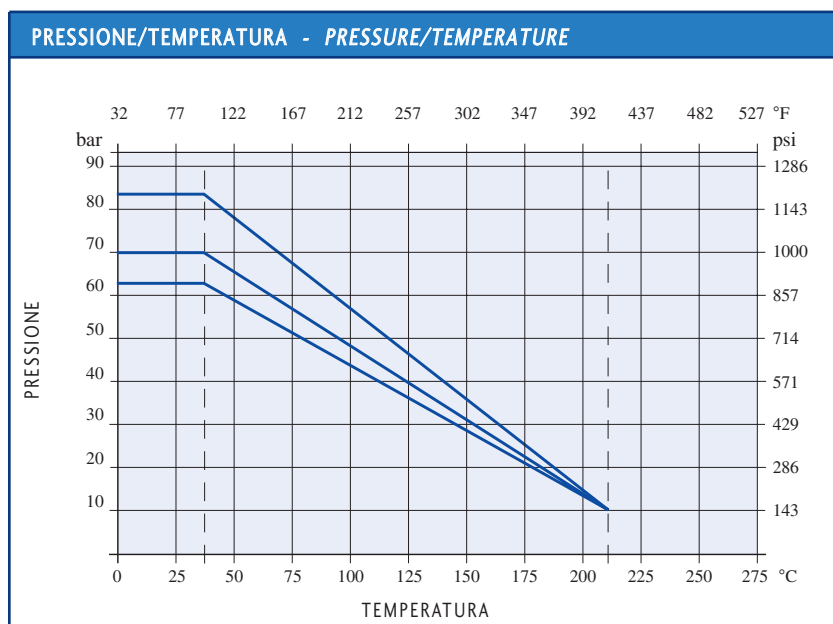
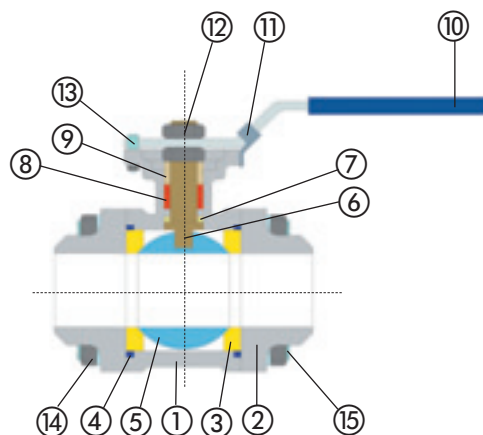

DATI TECNICI - TECHNICAL DATA

Pressione massima di esercizio Max working pressure	1/4" - 1" 85 bar 1 1/4" - 1 1/2" 70 bar 2" - 4" 65 bar
Temperatura massima di esercizio Max working temperature	-40°C + 220°C
Asta antiscoppio Anti blow-out stem	
Asta con testa quadra 45° Stem with square head 45°	ISO5211.73

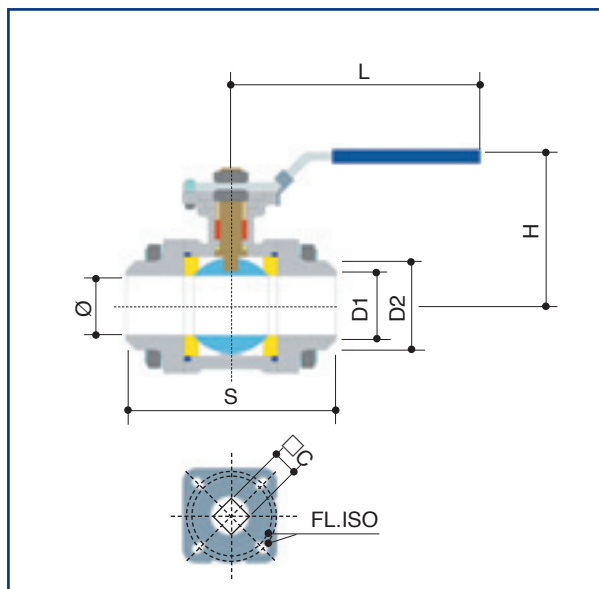

DN	1/4"	3/8"	1/2"	3/4"	1"	1"1/4	1"1/2	2"	2"1/2	3"	4"
Ø	11	12,7	15	20	25	32	40	50	65	80	100
S	48	48	55	74	81	91	103	120	142	182	220
D1	13	14,71	17	22	28	35	43	54	70	89	105
D2	18,1	18,1	21,7	27,2	34	42,7	48,6	60,5	76	93	116
H	62	63	68	72	75	90	95	102	140	162	170
L	117	117	117	135	135	135	203	203	260	260	280
FL.ISO	F03	F03	F03	F04/F05	F04/F05	F05/F07	F05/F07	F05/F07	F07/F010	F07/F010	F07/F010
□ C	9	9	9	11	11	14	14	14	17	17	17

Dimensioni in mm - Dimensions in mm

DIAGRAMMA PERDITE DI CARICO - FLOW AND PRESSURE DROP

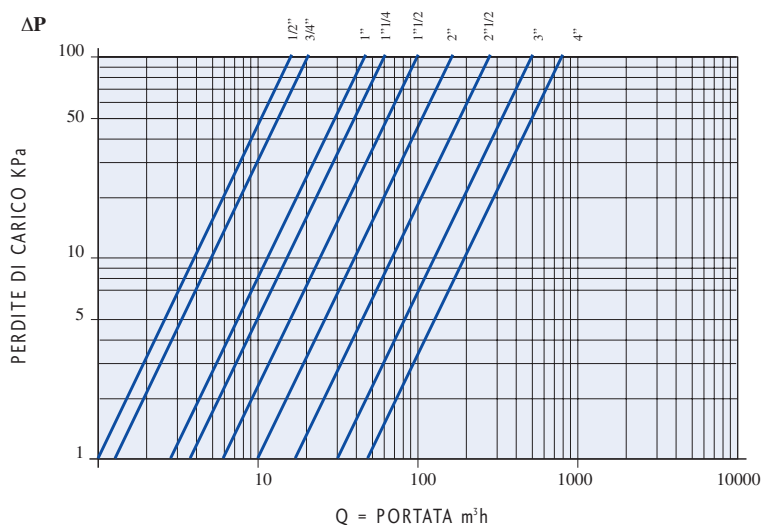

COEFFICIENTE KW - KW FACTOR

1/4"	15
3/8"	15
1/2"	20
3/4"	45
1"	60
1"1/4	100
1"1/2	170
2"	265
2"1/2	510
3"	790
4"	1230

AISI 316 VALVOLA A CLAPET - IVR 654



Valvola di ritegno a clapet in acciaio inox AISI316. Attacchi filettati gas F/F.
AISI316 stainless steel check valve. Threaded ends F/F.

Soupape de retenue à clapet en acier inox AISI316. Taraudage pas gaz F/F.
Rückschlagventil aus Edelstahl AISI316. Anschlussgewinde I/I.



IMPIEGHI: Le valvole a clapet serie 654 sono adatte per impianti industriali, chimici ed alimentari.

APPLICATIONS: The 654 series are suitable for use in industrial, chemical and food plants.

N. N.	DENOMINAZIONE PART NAME	MATERIALE MATERIAL	TRATTAMENTO TREATMENT
1	Corpo - Body	AISI316	
2	Otturatore - Disc	AISI316	
3	Vite - Screw	AISI316	
4	Guarnizione - Gasket	PTFE	
5	Guarnizione - Gasket	PTFE	
6	Tappo - Plug	AISI316	

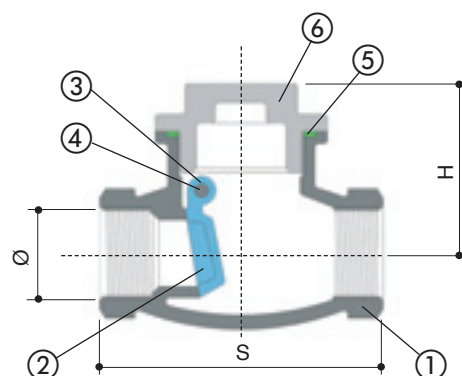

DN	1/4"	3/8"	1/2"	3/4"	1"	1"1/4"	1"1/2"	2"
Ø	10	12	15	20	25	32	37	50
H	42	42	42	50	50	57	65	81
S	64	64	64	78	85	101	117	136

Dimensioni in mm - Dimensions in mm

DATI TECNICI - TECHNICAL DATA	
Pressione massima di esercizio Max working pressure	16 bar
Temperatura massima di esercizio Max working temperature	-20°C +220°C

AISI 316 RACCOGLITORE D' IMPURITÀ - IVR 657



Filtro raccoglitore d'impurità in acciaio inox AISI316.

Attacchi filettati gas F/F.

AISI316 stainless steel inline filter.

Threaded ends F/F.

Filtre collecteur impureté en acier inox AISI316.

Taraudage pas gaz F/F.

Schmutzfänger aus Edelstahl AISI316.

Anschlussgewinde I/I.



IMPIEGHI: I raccoglitori d'impurità serie 657 sono adatti per impianti industriali, chimici ed alimentari.

APPLICATIONS: The 657 series are suitable for use in industrial, chemical and food plants.



N. N.	DENOMINAZIONE PART NAME	MATERIALE MATERIAL	TRATTAMENTO TREATMENT
1	Corpo - Body	AISI316	
2	Filtro - Filter	AISI316	
3	Guarnizione - Gasket	PTFE	
4	Tappo - Plug	AISI316	

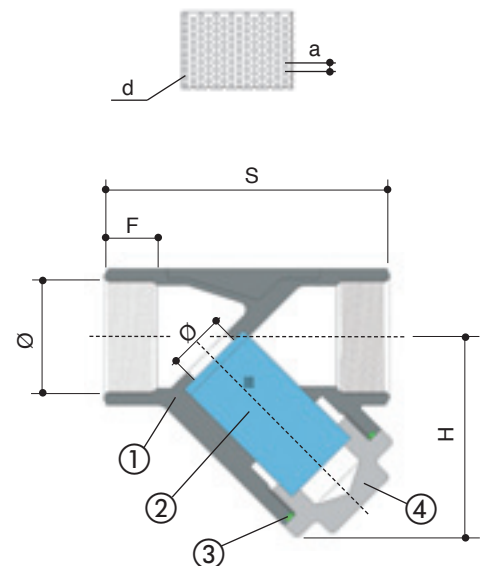

DN	1/4"	3/8"	1/2"	3/4"	1"	1*1/4	1*1/2	2"
Ø	10	12	15	20	25	32	40	50
S	64	64	64	80	90	106	119	140
F	13	13	13	14	16	20	20	23
H	43	43	45	52	68	70	80	98
d	1	1	1	1	1	1	1	1
a	2	2	2	2	2	2	2	2

Dimensioni in mm - Dimensions in mm

DATI TECNICI - TECHNICAL DATA	
Pressione massima di esercizio Max working pressure	40 bar
Temperatura massima di esercizio Max working temperature	-20°C +200°C

AISI 316 FLANGIATA CORPO PIATTO - IVR 685



Valvola a sfera a corpo piatto flangiata PN16.
 Corpo in acciaio inox AISI316. Flangetta ISO 5211.
AISI316 stainless steel ball valve.
Flanged ends PN16 - ISO 5211 top for actuator.
 Vanne à sphère à brides PN16.
 Corp en acier inox AISI316. Platine ISO 5211.
Kugelhahn mit Flansch PN16.
Körper aus Edelstahl AISI316. Flansch ISO 5211.



IMPIEGHI: Le valvole a sfera serie 685 sono adatte per impianti industriali, chimici ed alimentari.

APPLICATIONS: The 685 series are suitable for use in industrial, chemical and food plants.



N. N.	DENOMINAZIONE PART NAME	MATERIALE MATERIAL	TRATTAMENTO TREATMENT
1	Corpo/Flangia - Body/Flange	AISI316	
2	Guarn. corpo - Body seal	PTFE	
3	Seggio - Seat	PTFE caricato 15% vetro PTFE 15% glassfiber	
4	Sfera - Ball	AISI316	
5	Asta - Stem	AISI316	
6	Rondella - Seal	PTFE	
7	Guarn. asta - Stem seat	PTFE	
8	Premistoppa - Packing nut	AISI304	
9	Maniglia - Handle	AISI304	Rivestimento PVC - PVC coated
10	Rondella - Washer	AISI304	
11	Dado - Nut	AISI304	
12	Arresto - Stop pin	AISI304	
13	O-ring - O-ring	Viton	
14	Dado - Nut	AISI304	
15	Molla a tazza - Belleville washer	AISI301	
16	Rondella di fermo - Tab washer	AISI304	
17	Bloccaggio - Locking	AISI304	

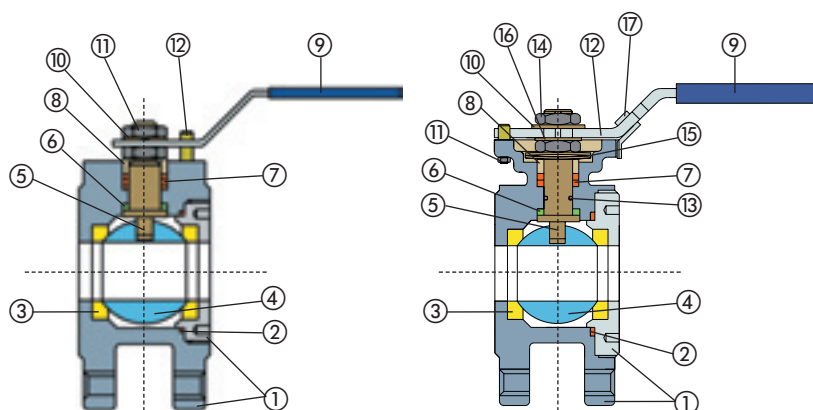

DN 15/20

DN 25/100

PRESSIONE/TEMPERATURA - PRESSURE/TEMPERATURE

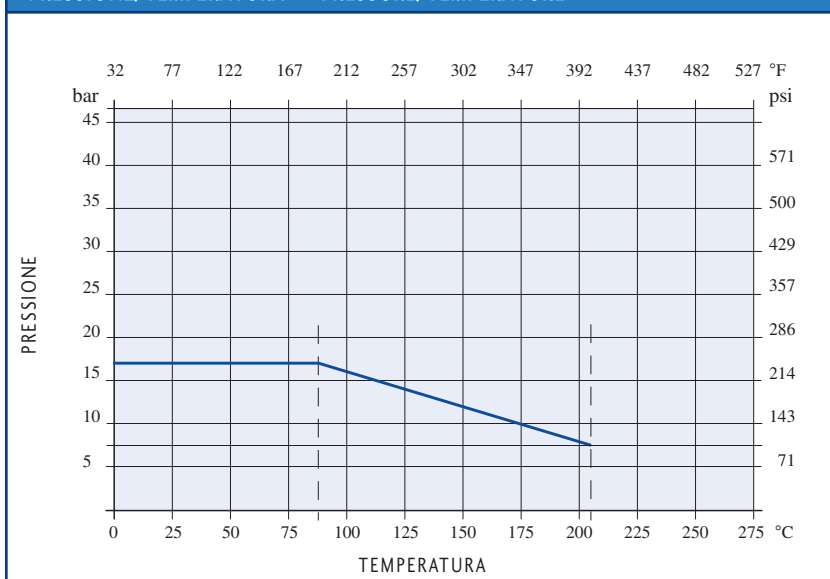

DATI TECNICI - TECHNICAL DATA

Pressione massima di esercizio Max working pressure	16 bar
Temperatura massima di esercizio Max working temperature	-20°C +220°C
Estremità flangiata Flanged ends	UNI-EN 1092
Asta antiscoppio Anti blow-out stem	
Asta con testa piatta Stem with flat head	ISO 5211

AIISI 316 FLANGIATA CORPO PIATTO - IVR 685

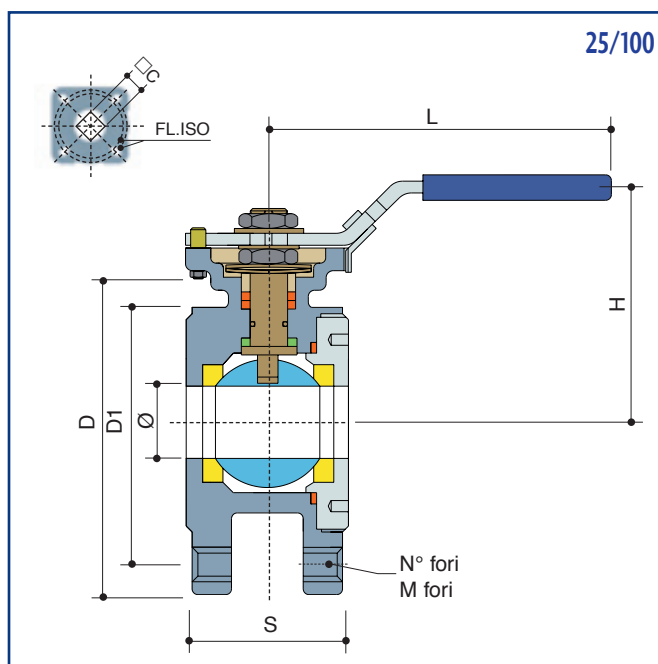
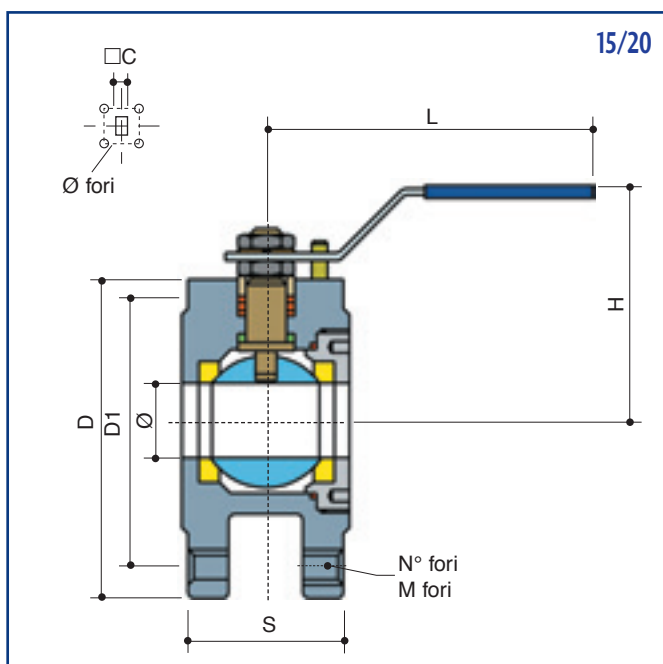

SIZE	15	20
Ø	15	20
S	36	38
H	80	85
L	150	150
D	95	105
D1	65	75
N° fori	4	4
M fori	M12	M12
Fl. ISO	F03	F03
Ø fori	36	36
□ C	9	9

Dimensioni in mm - Dimensions in mm

SIZE	25	32	40	50	65	80	100
Ø	25	32	40	50	65	76	94
S	50	53	65	78	98	118	140
H	95	100	105	115	130	195	175
L	170	170	210	210	260	260	260
D	115	140	150	165	180	200	220
D1	85	100	110	125	145	160	180
N° fori	4	4	4	4	4	8	8
M fori	M12	M16	M16	M16	M16	M16	M16
Fl. ISO	F04/F05	F04/F05	F05/F07	F05/F07	F07/F10	F07/F10	F07/F10
Ø fori	42	42	50	50	70	70	102
□ C	11	11	14	14	17	17	17

Dimensioni in mm - Dimensions in mm

DIAGRAMMA PERDITE DI CARICO - FLOW AND PRESSURE DROP

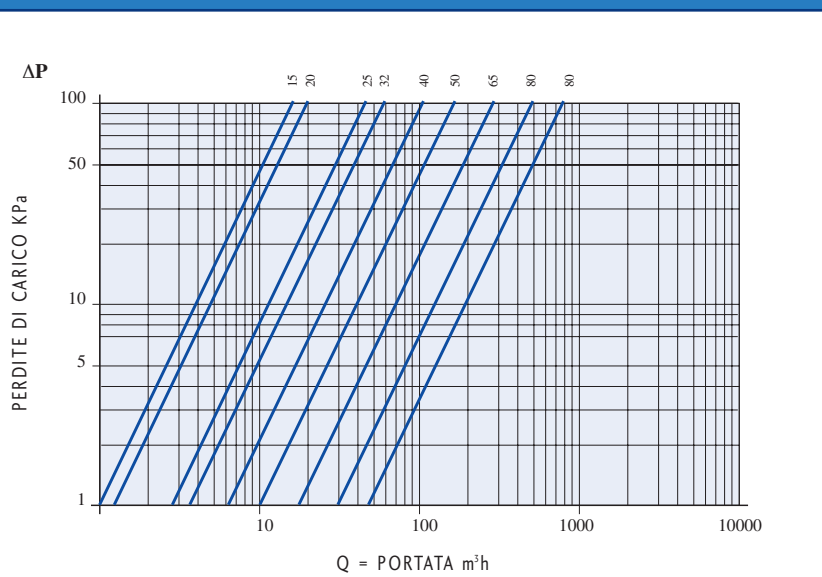

COEFFICIENTE KW - KW FACTOR

DN 15	20
DN 20	45
DN 25	60
DN 32	100
DN 40	170
DN 50	265
DN 65	510
DN 80	790
DN 100	1230

